

TRUFROST & BUTLER

USER MANUAL

**TWIN TWIST SOFT SERVE MACHINE:
2 Plus 1**



Content

I. Exploded Diagram 3

II. Installations& Adjusting..... 4

III. Operation Instruction..... 6

IV. Use & Maintenance 10

V. Trouble shooting guide 13

VI. Schematic wiring diagram..... 15

I. Exploded Diagram

Figure.1

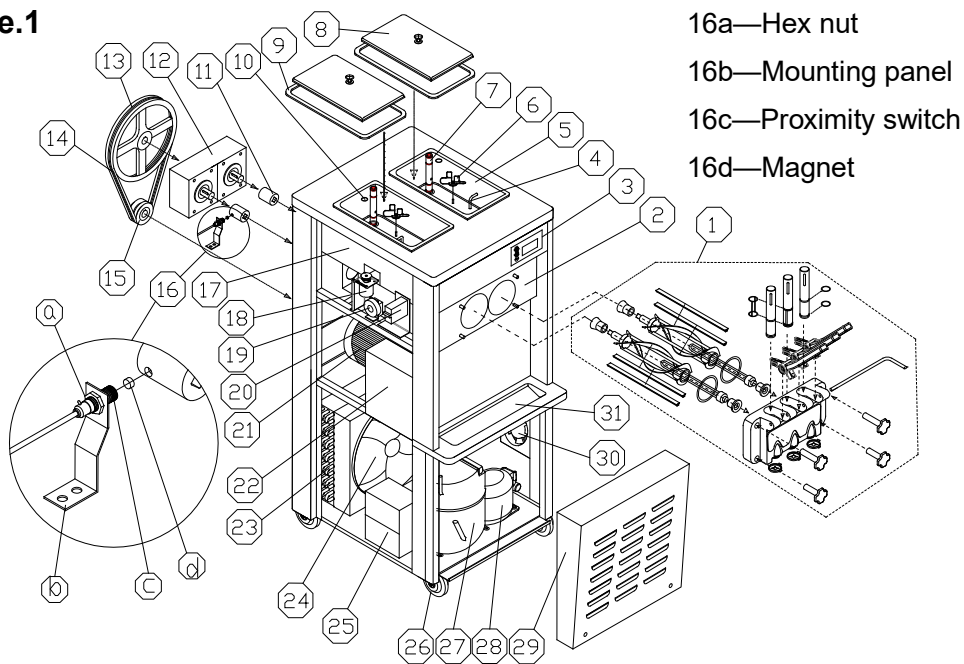

No.	Part Name	No.	Part Name	No.	Part Name
1	Dispener Door Assembly (figure3)	12	Gear Box	23	Condenser A
2	Dispenser Door Base	13	Driven Pulley	24	Fan A
3	Operation Panel	14	Belt	25	Accesories of Compressor
4	Mix Level Probe	15	Drive Pulley	26	Wheel
5	Hopper	16	Proximity Switch	27	CompressorA
6	Hopper Agitator	17	Evaporator	28	CompressorB
7	Feed Tube	18	Hopper Agitator Motor	29	Front Panel(Lower)
8	Hopper Cover	19	Hopper Thermostat	30	Fan B
9	Gasket of Hopper Over	20	Air Switch		Condenser BB
10	Plug of Feed Tube	21	Beater motor	31	Drip tray
11	Coupling	22	Electrical box		

Diagram for reference only, please in kind prevail !

II. Installations& Adjusting

A、 unpack & inspect

- 1) Cut off the wrapping tape.
- 2) Open the wooden case by screwdriver.
- 3) Remove the foam.
- 4) Inspect carefully whether there is defective appearance or not.
- 5) Check the accessories with packing list.
- 6) Remove the fixing bolt and fixing feet that are at the bottom of the machine, push the machine, let the front-wheel drive fall to the ground, and then take out the wooden base, let the four wheels grounded. (Directly lift the machine to the ground or on the table if the machine is table type)

TIPS:When first time using the machine, if there remains liquid residue in the cylinder.It's normal liquid residue caused by ex-factory cleaning and won't affect machine performance and its service time.If this causes any inconvenience, we feel sorry for that and thank you for your understanding.

B、 Installation

1) **SELECTING LOCATION**

- a、 Place the machine on a level counter that is stable and strong enough to safely support its weight.
- b、 Place the machine in a location that allows adequate space at the back and each side for proper ventilation. Keep 50cm space from all sides of ventilation. The machine should shade from the sun and should not be located too close to the units that radiate excessive heat.

2) **POWER SUPPLY**

- a、 Select the proper power supply according to the voltage and power on the nameplate.

b、 Connect the power wire and the power supply, ensuring the yellow and green wire was connected with the ground wire firmly.



Caution: a、 For safety, ensure the ground connection is in good condition.

b、 All the exterior wires and other appliances must confirm with national standard.

C、 Testing Running

1) Switch “ON” the power switch and you will hear “Beep”,all the graphic patterns on the screen will be lighted up and then the graphic patterns will extinguish,machine enters “Standby” mode.

2) Press “Wash”, the corresponding indicator will be lighted up and at the same time you will hear the sound of beater system working.Press the “Wash” button again,beater system will stop.

3)Press “Auto”,the corresponding indicator will be lighted up and the beater system will start working. After 3 seconds,the cooling system will also start working, air pumps in both hoppers enter normal working state.

D、 Clearing & Sterilizing

Step 1: Prepare 5-6 liters of warm water, mix with food detergent according to manufacture’s specifications. And this is the sterilizing solution.

Step 2: Pour the solution into the hopper While the solution is flowing into the freezing cylinder, brush and clean the mix hopper.

Step 3: Press the key of “clean”, and let the machine running for about 5 minutes.

Step 4: Place an empty pail beneath the draw spout and push down the draw handle. Draw off all solution.

Step 5: Repeat this operation for 2-3 times with water only.



Notice: a、 The temperature of the sterilizing solution can not overpass 60°C, or else it will damage the spare parts.

b、 Draw off all the water in the hopper after clearing, or else it will damage the beater while the compressor is running.

c、 While press the key of “clean”, pay attention to the indicator light in order to avoid pressing the wrong key.

III. Operation Instruction

A、 Key Instruction

Figure.2

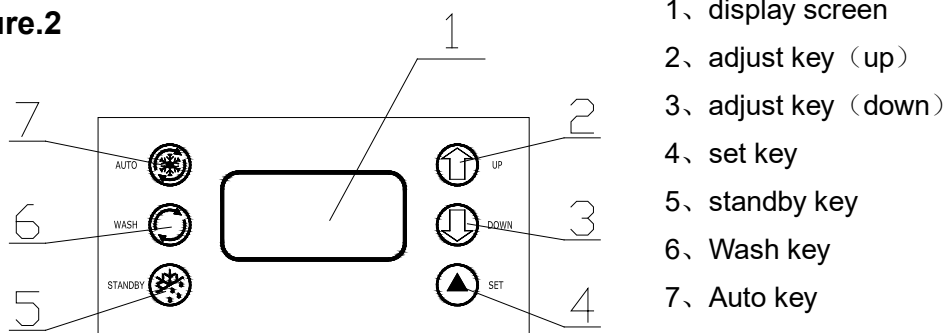

◆ SET KEY(UP / DOWN)

a、 set hardness level:

When the machine is ready mode, press “UP” or “DOWN” key for more than 2 seconds then the “SET” word on the displayer flashes and the number shows the setted level of hardness. For example, if the displayer shows “02” it means the current setting level is 2. The stiffness will increase one level each time that the “UP” or “DOWN” key is pushed. It circulate from “01” to “10” (01(soft)-02(hard)-03(harder)-----10(hardest)-01(soft))

b、 set parameters:

Machine in “standby”mode, press “UP” and “DOWN” at the same time and hold for 5 seconds,the “SET” window displays “P1” icon(Periodic Restarting Time Seeting), Press” ”,

the window will display "05"(The variable range is from "5~15" minutes, press"UP" and "DOWN" can change the setting volume)

Continue pressing "▲" key for two times, every time operation can change the icon display on the window. And when each icon appears,by pressing "▲"key for one time to change the setting you want.(Volume can be changed by pressing "UP" and "DOWN")

Icon	Implication	Variable Range
P1	Periodic Restarting Time Seeting	Range: 5~15 minutes
P2	Stop Delay of Beater Motor	Range:5~15 seconds
P3	No Specific Meaning	Range:5~15 seconds
P4	Hopper Pre-cooling Temperature Seeting	Range:10—80, indicates 1.0°C ~8.0°C
P5	Cylinder Temperature Setting	
P6	Cleaning Frequency	Range:2—14 , indicates 2~14 days
P7	Lack Mix Alarming Time Setting	Range:0—10 mins , "0"- Non-Stop

Press "▲" , the machine will enter circulatory volume setting. Without any operation in ten seconds, setting volumes will be automatically saved and back to the standby mode.

Time Setting

In standby mode, press the "AUTO" and "WASH" buttons for 5 seconds, the window shows "F1 01", then you can click the "UP" or "DOWN" key to adjust the back number.

Press "▲" key, the window shows "F2 12", by such analogy until " F7 30".

Note: F1 says mark symbol, 01、 02、 03.....30says actual value.

F1 -- week (00 - Sunday) F2 -- year F3 -- month F4 -- date

F5 -- hours F6 -- minutes F7 -- seconds

◆ WASH KEY

Press wash key "⊙", the "CLEAR" icon light and the beater starts to work. It will be closed when you press it again.

◆ STANDBY KEY

Press standby key, "STANDBY"and"FRESH"icon will light. The little compressor for

hopper is controlled by setting temperature. It will stop when the temperature is less than the setting value, and it will start again if the temperature in hopper raise for 2°C. When the temperature in cylinder is less than the setting value, the big compressor stops, after 15 seconds the beater motor stops. When the temperature in cylinder raise for 2°C, the beater motor start, after 3 seconds the big compressor starts. The temperature of hopper and freezing cylinder can be directly displayed on the screen.

◆ AUTO KEY

Press standby key, "AUTO" and "FRESH" icon will light. The little compressor for hopper is controlled by setting temperature. It will stop when the temperature is less than the setting value, and it will start again if the temperature in hopper raise for 2°C. The big compressor for cylinder will stop when the hardness value reach 99, after 15 seconds the beater motor stops. The beater motor will start again when the time goes for setting value (cycle time to restart for machine). After 3 seconds the big compressor starts.

◆ PROTECTION FUNCTION



- ✧ The sensor for freezing cylinder is open circuit or short circuit, hardness window on the screen will show "RL" or "RH", the buzzer will scream and the machine stop.
- ✧ The sensor for mix hopper is open circuit or short circuit, hardness window on the screen shows "RL" or "RH", the buzzer screams, and the machine stop.
- ✧ When the machine is in "WASH" or "AUTO" mode, if the digital display shows "— —" with alarm and machine stopping, and keys on the operation panel will be locked. That means the proximity switch is damaged or not in correct position. Change it or put it in the correct position.
- ✧ When the digital display shows "NL" with alarm and machine stopping, means the belt of beater motor system is skidded.
- ✧ If pushing the handle for more than 1 minute, hardness window on the screen will show "Cb", the buzzer will scream and the machine stop.
- ✧ Under "AUTO" or "STANDBY" status, if mix lack, hardness window on the screen will

show "CL" and hardness alternately, the buzzer will scream for 20 seconds.

- ✧ The number "01" will flash if just 1 day left for the setting cleaning cycle. When the cleaning cycle is over, the window will show "OVER", and the buzzer works intermittently. Then you just can use "WASH" and "PUMP" functions. The refrigeration function is locked, and only can be unlocked after switch power off and on again. The cleaning cycle will count anew.
- ✧ Less cooling, no cooling, or cooling over one hour still ice cream not forming, the screen will display "ERR", and sound of "BEEP" will continue.

B、 Make Ice Cream

1) MAKE SURE THE MACHINE IS CLEAN AND SANITIZED BEFORE MAKING ICE CREAM.



- a、 Prepare some sanitizing solution with warm water (temperature between 50°C and 60°C), pour it into the hopper and clean the wall of hopper.
- b、 Turn on the power switch, and then press "  " and operate for 5 minutes.
- c、 Put an empty pail under the dispensing door, pull down the handle for 3 seconds, and then return back by hand. Repeat it in this way for 6 times to clean the mix pump assembly thoroughly.
- d、 Draw out all sanitizing solution from machine and turn off "  " .
- e、 Take off the 4 screws from dispensing door, then remove the dispensing door assembly. Disassemble it, and put them into the sanitizing solution to clean thoroughly. And then assemble them together and put it on the machine.
- f、 Pour some clean water into the hopper and repeat to rinse it for several times.
- g、 Use clean towel to wipe water off dispenser door.

2) PREPARE THE MIXER

Prepare the ice cream mixer as the instruction of your purchased ice cream powder or liquid mixer. Make sure the liquid mixer without any impurities or particulate. And keep it for 15 minutes or keep it into the freezer.

3) MAKE ICE CREAM

Notice: When you select another new ice cream mixer to make ice cream, please set the hardness level to "02" to make ice cream. And adjust the hardness level properly as dispensed ice cream.



- a、 Pour half fresh mix into the hopper.
- b、 Press "  ", until the inlet hole of pump cylinder without bubble. It's not good for ice cream shape if you don't operate in this way.
- c、 Add more ice cream mixer into the hopper, put the hopper cover on.. Press "  " key to start operation. The number on the digital display will rise up during operation. When the number reach "99", the ice cream in the freezing cylinder is ready for serve.
- d、 Dispensing ice cream. Put a cone or other containern under the dispenser door, pull down the handle to get ice cream. Then push it back after dispensing.
- e、 Clean the machine after daily work. Dispensing all the ice cream in the freezing cylinder and mixer in the hopper. Clean and sanitize machine as above instrouction.

IV. Use & Maintenance

Different machines must be used and maintained according to their different using conditions and environment conditions.

A、 Washing Refrigeration Cylinders

Clean the refrigeration cylinders once everyday for a longer useful life and for the health of customers.

- 1) Press "  " key to exhaust all the remaining slurry in the beverage containers and refrigeration cylinder, then click "  " key , the machine will stop;
- 2) Take the right amount of food detergents, make up disinfecting solution according to it's instruction with warm water, then put the solution into each bucket;
- 3) Press the "  " key, after the machine stirring about 5 minutes, discharge the disinfecting solution, followed by washing with water 2~3 times, then stop the machine;
- 4) Turn off the power, take apart and wash the parts.

- a. Unscrew the four fastening screws in front of the dispenser door, remove the dispenser door;
- b. Remove the components as follow: pin of handle, handle, piston, O-ring for piston and O-ring for dispenser door from the dispenser door;
- c. Draw the beater from the refrigeration tank, then remove the gasket for beater.

Fig.3 A

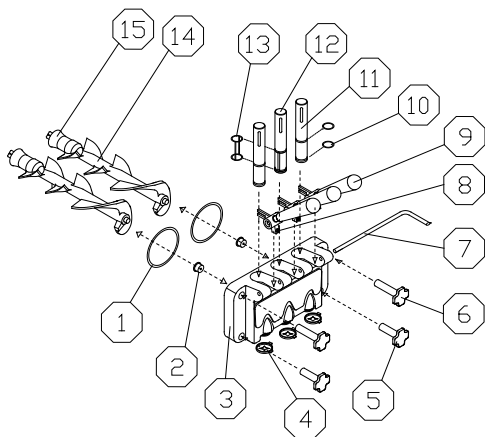

- 1、 O-ring for dispenser door
- 2、 supporting sleeve
- 3、 dispensing door
- 4、 modeling cap
- 5、 down bolt
- 6、 upper bolt
- 7、 pin for handle
- 8、 screw for handle
- 9、 handle
- 10、 O-ring for piston
- 11、 piston
- 12、 middle piston
- 13、 O-ring for middle piston
- 14、 beater
- 15、 gasket for beater

Fig.3 B

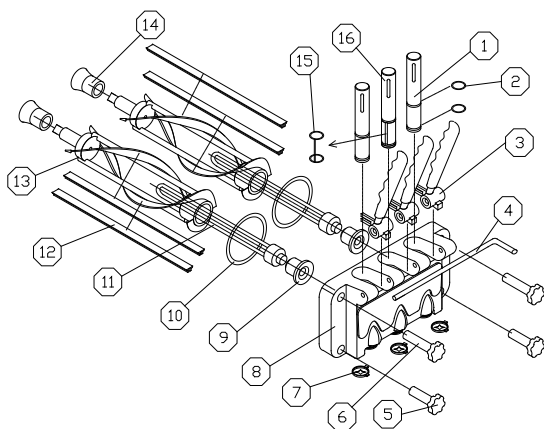

- 1、 piston
- 2、 O-ring for piston
- 3、 handle
- 4、 pin of handle
- 5、 screw nut (down)
- 6、 screw nut (up)
- 7、 Modelling cap
- 8、 dispensing valve
- 9、 supporting sleeve
- 10、 gasket for dispensing valve
- 11、 flow plug
- 12、 blade
- 13、 beater
- 14、 gasket for beater
- 15、 New design middle piston O-ring
- 16、 New design middle piston

- d. Put the components into disinfecting solution to clean, check the beater, gasket for beater, O-ring for dispenser door, supporting sleeve and O-ring for piston, if they are worn oldly, they should be replaced;
- e. After cleaning, lubricate the parts with vaseline, then install the parts according to the method of taking apart.

Fig.4

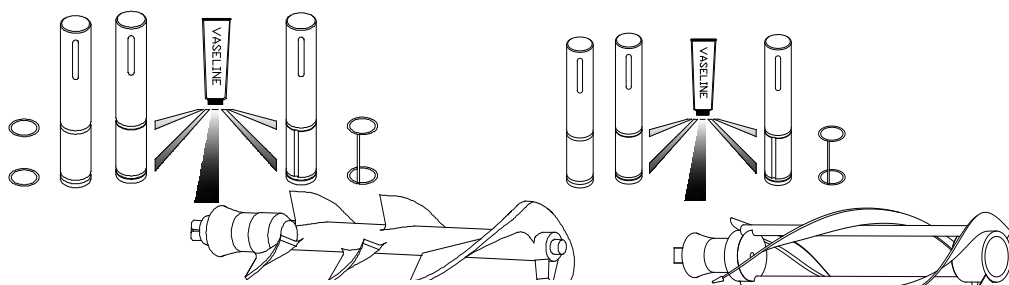

Notice: Before installing the piston, O-ring for piston, beater and gasket for beater, you should lubricate vaseline (lubricating vaseline onto the groove of the gasket, do not onto the beater's end), using the vaseline frequently can extend the service life of components.

B、 Cleaning Machine Cabinet

Keep the machine cabinet clean, use wet towel to clean the cabinet, and do not flush the machine with water directly.

C、 Cleaning Condenser

After be used over a period of time, the condenser maybe thick with dust, and this will effect radiate heat and cause refrigeration difference, so it needs periodic cleaning (every half year)

Cleaning methods:

Step 1: Disconnected the main power switch.

Step 2: Remove the back panel and side panels.

Step 3: Clean dust with tools such as vacuum cleaner, high-pressure air and hairbrush, be careful while cleaning to avoid damaging the fins of the condenser.

D、 Belt Adjustment

After be used over a period of time, the belt of the machine maybe elongated, so it needs to be adjusted. Disconnected the main power of the machine, remove the back panel and side panels, adjust the tension bolt and make sure the belt is in appropriate tension.

V. Trouble shooting guide

Problems	Probable cause	Remedy
Machine does not run	Machine not plugged into the wall receptacle	Plug machine in
	The short-circuiting switch is open	Restart it after it was repositioned
	Protect circuit	Remove the trouble
Machine in clean position does not run	The connecting wire is unfastened	Check and fasten the wire.
	The beater motor broke	Repair or change the beater motor
	Mini circuit breaker was broken.	Find and solve the problem then reposition it
Machine in auto position does not run	The wire of function switch is unfastened.	Check and fasten the wire.
	There is some problem with control panel.	Change the control panel.
Compressor does not run	Low voltage	Solve the problem of low voltage
	Contactor broke	change contactor
	The relay of the compressor broke	Change the control panel.
	There is some problem with control panel.	Change the control panel.
	The self-protection of the compressor because of overload.	Find and solve the problem
	The compressor broke	Change the compressor
	The capacitor of the compressor broke	Change the capacitor
Machine do not freeze down	Leakage of the refrigerant	Find and repair the leak in the pipe, then vacuum and recharge the refrigerant
	Electrical valve broke	Change the electrical valve
	Fan motor do not run	Repair or change the fan motor

	The capacitor of the fan motor broke	Change the capacitor of fan motor
Machine non-stop	The set point is too low	Increase the set point
	There is some problem with control panel.	Change the control panel
	Refrigeration difference	Check and repair the refrigerating system
The relay is not stable	Low voltage	Solve the problem of low voltage
	There is some problem with control panel.	Change the control panel.
	The touch point of the contact switch broke.	Remove the touch point or change the contact switch.
Product does not dispenser	The proportion of mix is incorrect, and causes the refrigeration difference	Make up a proper proportion of mix.
	No mix in the hopper	Pour the mix into the hopper
	Limit switch broke or the tie wire is unfastened.	Change the switch or fasten the wire
	The belt is unfasten or skid around	Change or adjust the belt
	The bearing sleeve or the beater shaft worn	Change the bearing sleeve or the beater shaft.
The product too soft	The proportion of the formula is wrong	Compound the mix according to the formula given by the supplier.
	The set point is too low	Increase the set point
Leakage	Draw piston leaking	Reassemble or change the O-ring.
	Dispenser door leaking	Tighten the screws or change the D-ring
	Drip tube leaking	Fix well or change the Gasket for beater
Warm rings	Low voltage protection	Stop the machine, solve the problem and restart 5 minutes later.
	Stop working for protection	Stop the machine, solve the problem and restart 5 minutes later.

	The limit switch can not return to normal	Push down the handle and let the limit switch return to normal.
Nixie tube display “NL”	The belt skid or the motor lose speed	Adjust or replace the belt, solve the fault of motor
Nixie tube display “___”	The proximity switch deflect or broke	Adjust or replace proximity switch

VI. Schematic wiring diagram

- Technology parameters are on the nameplate
- The electrical schematic diagram is on the board inner

Marketed globally by

TRUFROST AND BUTLER PRIVATE LIMITED

1215, 12th Floor, Tower B, Emaar Digital Greens, Golf Course Extn. Road,
Sector 61, Gurugram - 122011, India

T. +91-7303166766 info@trufrost.com

www.trufrost.com