

**TRUFROST & BUTLER**

# **USER MANUAL**

**Commercial Ice Flaker:**

**IF-200**

**IF-300**

**IF-500**

**IF-1000**

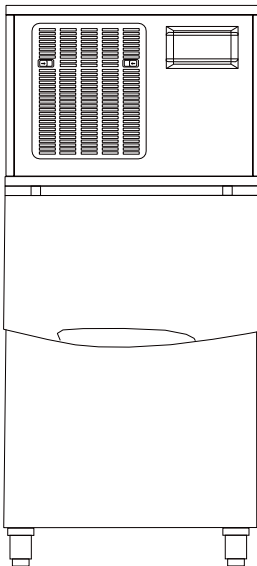

The instruction manual is an integral part of this product, please keep it properly. The user must read carefully, especially the safety description in the manual, as well as the installation and maintenance information.

# Contents

Important safety instructions .....	3
Overview.....	4
Transportation and installation environment inspection and precautions.....	4
Working conditions and performance parameters .....	4
Machine installation steps.....	5
Machine operating instructions.....	8
Equipment maintenance .....	11
Circuit diagram .....	13
Factory parameter setting table .....	14
After-sales service and warranty .....	14

## Important safety instructions

1. This flake ice machine is a commercial device and is only suitable for the purpose specifically designed for the device. Any other use is considered improper use and may cause danger. For any losses caused by improper, incorrect and unreasonable use of this product, the manufacturer does not assume any legal and related responsibilities.
2. Installation and relocation operations when it's necessary must be carried out by professionals with appropriate knowledge in accordance with current regulations and the manufacturer's instructions.
3. ★Note: All parts have been adjusted before leaving the factory. Improper adjustment may cause malfunction. After turning off the ice maker, wait at least 3 minutes before restarting the ice maker to prevent damage to the compressor.
4. Keep the air vents inside and outside the machine unobstructed.
5. When using any electrical equipment, you should follow some basic rules, especially: high humidity and moisture will increase the risk of electrical short circuits and potential electric shocks. If there is any suspicious situation, please cut off the power of the ice maker.
6. When disconnecting the ice machine from the power supply network, do not damage or pull the power cord.
7. Do not touch electrical parts or operation switches with wet hands.
8. This product is not suitable for people who lack the corresponding experience and knowledge to use it alone, unless someone is responsible for its safety and supervises and guides its use of this product.
9. Be sure to supervise young children to ensure that they do not play with this product.
10. Do not modify this machine. Dismantling or maintenance should only be carried out by operators with appropriate knowledge.

## I .Overview

Before installing, debugging, and using the flake ice machine, please read the instruction manual in detail. This instruction manual introduces the operating conditions, performance parameters, installation and debugging, operating procedures, etc. of the company's flake ice machine. Please use with our company's special ice storage bin.

## II . Transportation and installation environment inspection and precautions

1. During transportation and handling, do not bump, shake, tilt, place it horizontally, or invert it, otherwise it will cause the internal parts of the machine to become loose or damaged.
2. Intact inspection of parts.
3. Check that the package is not damaged.
4. Check whether the model is consistent with the order.
5. Check whether the internal parts of the machine are loose or damaged.
6. Check whether all pipe connections (water system, refrigeration system, etc.) and electrical connections (wires, PC boards, etc.) are intact.

## III. Working conditions and performance parameters

### 1. Working conditions

	Minimum	Max
Ambient temperature	1 °C	40 °C
Inlet water temperature	5 °C	35 °C
Water pressure	0.15Mpa	0.55Mpa
Rated voltage deviation	-10 %	+6 %

2. Refrigerant charge amount: see nameplate
3. Power and other parameters: see nameplate
4. Installation environment inspection and precaution

① The socket and wiring must comply with the electrical specifications and the requirements on the nameplate of the machine!

- ② According to the machine nameplate parameter requirements, select the appropriate air switch, and the air switch must be installed within reach.
- ③ The sockets or other power supplies provided on site must be installed with a ground wire in accordance with relevant requirements, and a reliable connection to the machine ground must be ensured.
- ④ The on-site water supply must ensure continuous water supply (pressure level 0.15Mpa~0.55Mpa), the water source switch must be installed near the flake ice machine, the water inlet and drain pipes must be independent, and the water outlet must also be near the flake ice machine. The flake ice machine and storage two separate drain pipes are used to drain the ice bucket.
- ⑤ The machine should be far away from heat sources, and should not be installed near stoves, ovens, water boilers and other high-temperature equipment. The surrounding environment should be ventilated, dry, and non-corrosive.
- ⑥ This machine is not suitable for outdoor use.
- ⑦ A pre-filter or water processor can be installed under the guidance of a full-time installer according to the water quality in various places.

## IV. Machine installation steps

1. Know the machine: Figure 1 shows the rear interface of the machine

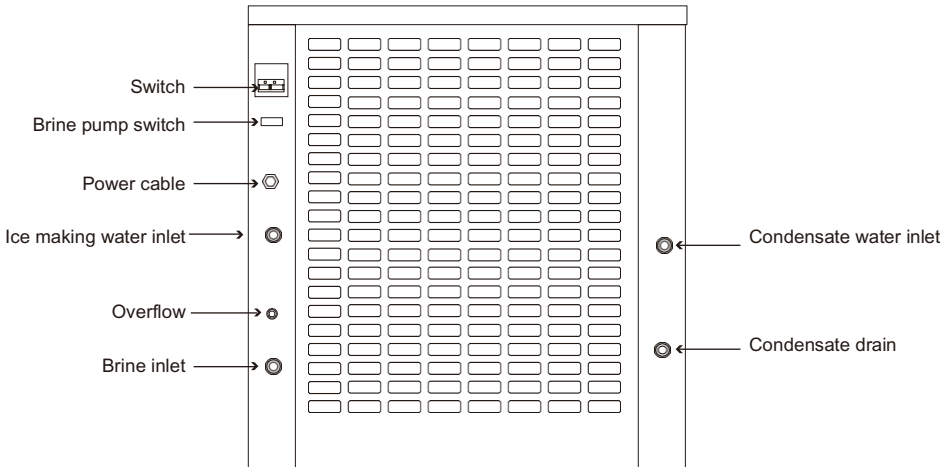
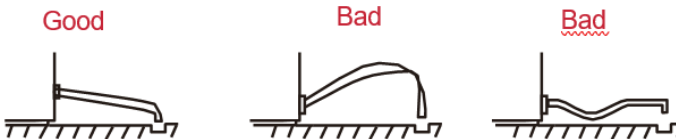

Figure 1

2. Ice storage bin installation: install the ice storage bin and adjust the 4 supporting feet of the ice storage bin to keep the ice storage bin horizontal and vertical.
3. Placement of the machine: Place the machine horizontally on the upper part of the ice storage bin, and the rear is basically level with the back of the ice storage bin.
4. Connect the water source: Connect the water pipe in the accessory box to the machine according to Figure 1. But the premise is: the water pressure is within the allowable water pressure range. If the water pressure exceeds the maximum allowable pressure of 0.55Mpa, please add a pressure reducing valve or contact our company to buy a pressure reducing valve.
5. Install the drainage pipe: Connect the drainage pipe of the accessory to the drainage interface of the machine according to Figure 2. When installing the drain pipe, it must be laid as shown in the figure below to prevent the drained water from being unable to drain, and even the discharged sewage will flow back into the ice maker or ice storage bin. The ice machine drains water by gravity, so it is necessary to ensure that the drain pipe has a sufficient slope or drop. Connect the drain pipe directly to the sewer system, leaving at least a 5cm vertical gap between the end of the drain pipe of the ice maker and the ground drain.

Figure 2



6. Connect the power supply: Refer to Figure 1 to connect the main power supply of the machine. The grounding wire must be reliably connected to the grounding wire of the machine! Warning!
7. Keep the distance between the surroundings: a proper distance should be kept around the machine (water-cooled machine can be appropriately reduced) for smooth ventilation and easy maintenance.

Refer to Figure 3

Figure 3

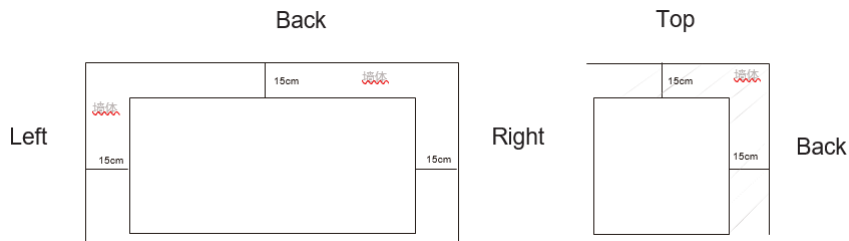

8. Final inspection: Fill in the following installation checklist to ensure the correct installation of the machine:

Check item	Result	Remarks
Whether the packaging inside and outside of the machine and the fixings for transportation are all removed		
Whether the ice maker and ice storage bin are placed horizontally		
Whether the water and electricity part is fixedly connected according to the requirements		
Whether the water inlet valve has been opened		
Whether the drainage is unobstructed		
Whether the supply voltage is the same as that on the nameplate		
Whether the surrounding clearance meets Figure 3		
Is the working environment of the ice maker at 1~40℃		
Is the inlet water temperature of the ice maker 5~35℃		
Whether the machine has been reliably grounded		
Whether to fill out the warranty card		

## V. Machine operation instructions

### 1. Control Panel

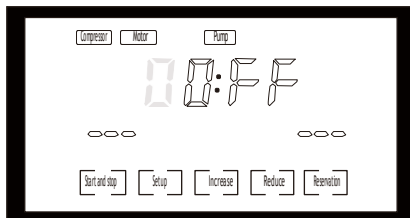

Figure 4

### 2. Instructions

- ① Power-on state: power-on default shutdown state, display OFF.
- ② Shutdown state: In the ice making state, short press the "Start/Stop" button to start the countdown, and enter the shutdown state after the countdown ends.
- ③ Ice making state: In the shutdown state, short press the "Start/Stop" button to start the countdown, and enter the ice making state after the countdown is over.
- ④ Appointment function: scheduled shutdown function, enter the shutdown state after the time is over.

**Start and stop appointment:** In the working state, click the "appointment" button to start the appointment function, and the appointment icon will light up;

**Close appointment:** click again to close the appointment, and the appointment icon closes;

**Appointment time setting:** In the work mode, click the "Set" button to enter the time appointment setting. Press "plus and minus" to set, the range is 1 minute to 10 hours; click the "set" button again to exit or automatically exit without operation for 5 seconds.

- ⑤ Ice full state: The photoelectric detects that the ice is full, the ice full icon flashes on the display screen, continue and confirm the ice full, execute the shutdown process, enter the ice full state, and the ice full icon lights up.
- ⑥ Ice full release status: When detecting that the ice is not full, the full ice icon on the display will flash for a second, exit the full ice state after a delay, and start the ice making process.

### 3. Fault state

- ① Compressor and motor overload-detect the compressor or motor overload and stop directly.

- ② High-voltage failure-when the high-voltage switch is continuously disconnected, it enters a failure state, and the display shows high-voltage failure.
  - ③ Low-voltage protection-delay to start the low-voltage detection function after each startup.
  - ④ High temperature fault—Under normal circumstances, the evaporation temperature of the condensation probe on the main board is too high to trigger high temperature protection, and the display will light up the fault icon.
  - ⑤ Water level detection-when the water level sensor detects water shortage, the icon "Water shortage protection" flashes on the display screen to confirm that there is no water continuously, and the display screen displays a "water shortage" fault; When water is detected, the icon "Water shortage protection" flashes for a second, and it is continuously confirmed that there is water.
4. View the condensing temperature-in the working state, click the "increase" or "decrease" button to display the condensing temperature, click again to exit or automatically exit after 10 seconds.
  5. Emergency state-when the ice full photoelectric switch is invalid, long press the "reservation" button for 3 seconds to enter the emergency ice making state, this state will shield the full ice detection, and automatically turn on the timer shutdown function (this state cannot turn off the scheduled shutdown function, reservation Time can be set).When the water tank is powered on for the first time, there is no water, the water shortage protection light is on, and the light is off when the water is filled, and it starts after pressing "Start/Stop".  
  
★ Note: The left side shows the compressor current, and the right side shows the motor current.
  6. Turn on the main switch of the machine: After checking that the machine is installed correctly, turn on the main switch on the back of the machine.
  7. Steps to start the ice maker: Please follow the steps below to start the ice maker for the first time after installation.
    - ① Close the main power air switch.
    - ② Open the water inlet valve to ensure unobstructed water inlet.
    - ③ After clicking the "Start/Stop" button, the machine can be started (note that there is a delay in starting).
    - ④ Make sure that the direction of rotation of the ice scraper is correct-the ice scraper rotate in a counterclockwise direction.
    - ⑤ After the machine is running, observe whether the water level of the drip tray is correct from the transparent window on the top of the evaporator. If it is not correct, adjust the valve on the water pump. Note that the water level in the drip tray has been

adjusted to the best water level line when the machine leaves the factory, please do not adjust it up or down arbitrarily. If the water level is indeed too low or too high, you can adjust the valve in the water tank to make the water level reach the right position (the water level is about 26mm from the bottom of the water divider).

⑥ After the machine runs normally for 2-5 minutes, observe the condition of the ice layer on the inner surface of the evaporator, whether there is abnormal noise when the ice scraper scrapes the ice, and whether more than 90% of the ice on the icing surface has slipped.

⑦ Run the machine for about 20 minutes, and check if there are other abnormal sounds besides the normal sounds of the compressor and ice scraper.

◆ Whether there is abnormal vibration in the refrigeration pipeline.

◆ Whether the water tank cover is loose.

⑧ Check whether the full ice controller can be used normally, and whether the liquid level controller in the water tank is working normally. Follow the steps

①.②.③ for normal startup.

## 8. Full ice and fault description

① Ice full state: When the ice in the ice storage bucket reaches a certain height, the ice full photoelectric sensor at the bottom of the ice maker will act, and the ice maker will stop with a delay, and the ice full icon will flash on the display screen. Continue and confirm that the ice is full to execute the shutdown process, enter the ice full state, and the ice full icon is always on. After taking ice, when the height of the ice in the ice storage bucket drops to a certain position, the ice full photoelectric sensor is automatically reset, the ice full icon on the display flashes, the system will automatically turn on after a certain delay, and the ice full icon on the display will go out after normal work. It can also be turned on manually.

② Water shortage failure: When the ice making water in the water tank does not reach the fixed water level, the display icon "Water shortage protection" flashes after the water level sensor detects the lack of water, and it continues to confirm that there is no water, the display shows the water shortage failure, and the ice maker stops immediately. Running, the water shortage indicator on the display is always on. The user checks whether the water supply pipeline is normal to ensure that the water supply is normal and the ice-making water in the sink reaches the specified water level, and the water level switch is reset. After the user clicks the function button to manually clear the fault (if the actual water shortage fault still exists, the manual clearing is invalid), the water shortage indicator goes out, and then clicks the button, the ice maker starts with a delay and enters the normal operation state.

③ Failure of phase loss or wrong item: When the phase power system has phase loss or phase error, the ice maker will automatically stop running immediately, the corresponding indicator on the display screen will always be on, and the user will

check the electrical circuit. After troubleshooting, the corresponding indicator light will go out, and then click the button, the ice maker will start with a delay and enter the normal operating state.

- ④ Compressor and reducer overload fault: When the compressor and reducer current overload, the ice maker will immediately stop running, and after the fault is removed, it can start and run normally.
- ⑤ Unbalance, high pressure, low pressure failure: When the refrigeration system has pressure imbalance or high pressure, low pressure failure, the corresponding pressure switch will act, and the ice maker will stop running immediately. As mentioned above, after troubleshooting and manually removing the fault, click the Start/Stop button again, and the ice maker will start with a delay and enter the normal operating state.

## VI. Equipment maintenance

1. Maintenance must pay attention to the following operation matters:

- ① Before maintenance, the power supply must be cut off.
- ② Maintenance must be completed by qualified professionals.
- ③ Please read the manual carefully before maintenance.
- ④ The manufacturer of this machine is exempt from liability for the consequences of water sanitation responsibilities and illegal operations.

2. Daily maintenance of customers:

- ① Regularly remove dust on the surface of the machine.
- ② Regularly remove the scale inside the water tank, the water divider, and the evaporator.
- ③ Regularly check whether the water pipe of the drip tray is unobstructed.
- ④ Regularly check whether the lubricating oil level of the reducer is normal and whether the fixing screws are loose.
- ⑤ Regularly check whether the ice full sensor is misplaced or deformed.
- ⑥ The gear oil of the reducer is replaced once a year.
- ⑦ On average, use a soft cloth to clean the inner wall of the evaporator, the drain pan, and the water tank every two months.
- ⑧ Clean the air-cooled condenser regularly.
- ⑨ Clean the filter regularly (at least twice a month).

The steps are shown in Figure 5:

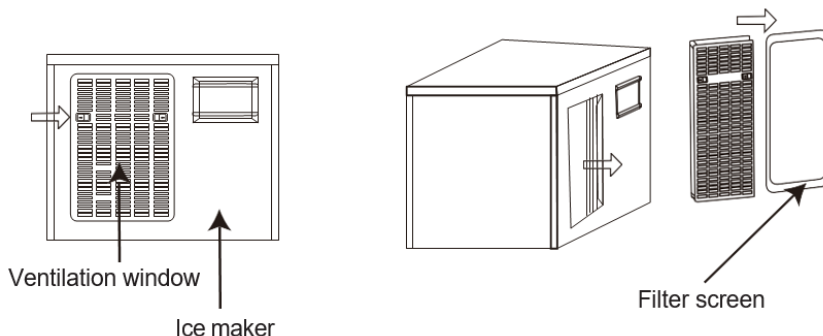

Figure 5

3.Special maintenance: This maintenance needs to be performed by our company's maintenance personnel or trained and approved personnel.

★Note: When disassembling the ice machine, please put all the parts away and disassemble and debug according to the drawings.

★Note:The ice flakes in the storage bin should be emptied during the cleaning process to avoid contamination by cleaning agents.

The cleaning steps are as follows:

- ① Cut the power supply.
- ② Prepare a container for the preparation of cleaning agents, purchase professional cleaning agents for ice machines, and prepare the solution with water.
- ③ Pour the cleaning agent into the water tank slowly and close the water inlet valve of the water inlet pipe at the same time.

★Note: Note: Please read the cleaning agent instructions carefully to avoid safety accidents.

- ④ Connect the power of the machine, let it run for about 10 minutes, and cut off the power.
- ⑤ Then drain the sewage, open the water supply valve to enter the water, and then connect the power supply to wash with clean water for 10 minutes, then replace the sewage.
- ⑥ Pour the cleaning agent into the water tank, run for about 5 minutes, and replace the cleaning agent.
- ⑦ Finally, rinse with clean water.

4. When not using the ice machine for a long time:

- ① ★Note: This ice maker cannot work at temperatures below freezing. To prevent damage to the water supply pipeline, when the temperature is below zero, drain the water in the ice maker.
- ② When the ice maker is shut down for 2 days or more, please empty the water inside to prevent waterway pollution.
- ③ Unplug or disconnect the ice maker.
- ④ Turn off the water supply tap, and then remove the water inlet hose.
- ⑤ Remove all ice in the ice storage bin and clean the ice storage bin.

VII. Circuit diagram

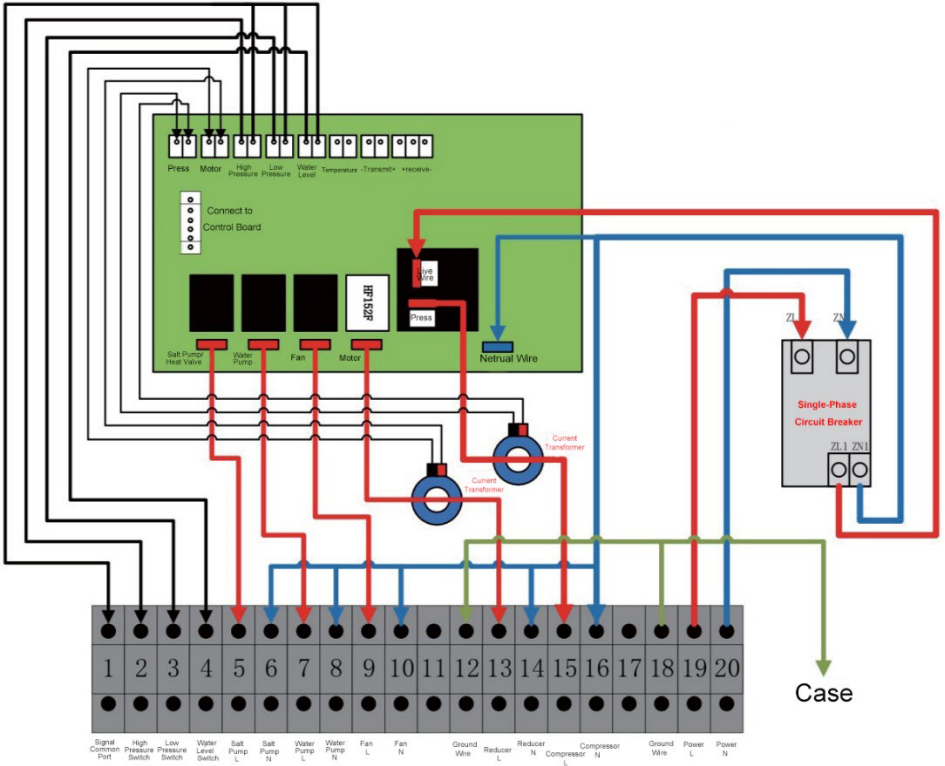

## VIII. Factory parameter setting table

Item	Function description	Option range	Defaults	Remarks
1	Boot delay	1-20 minute	1 minute	
2	Shutdown delay	1-20 minute	1 minute	
3	Compressor protection current	0.1-25.0A	10A	
4	Motor protection current	0.1-25.0A	2.5A	
5	Valve definition	OFF-None VALV- Balance valve PUMP- Salt pump	2.5A	When setting "PUMP", start and stop together with the water pump: When "VALV" is set, the press will work for 30 seconds before starting.
6	High and low pressure detection set	ON-Detection of high and low pressure HPON- Only detect high voltage LPON- Only detect low pressure OFF- Does not detect high and low pressure	ON- Open all	Low pressure detection turns on after 10 minutes of compressor startup

## IX. After-sales service and warranty

After confirming the installation and commissioning, please keep this instruction manual and warranty card properly to facilitate future maintenance services.

We will serve you whole-heartedly!

**TRUFROST AND BUTLER PRIVATE LIMITED**

1214 & 1215, Tower B, Emaar Digital Greens,  
Golf Course Extn. Road, Sector 61, Gurugram – 122011, Haryana, India  
T. +91-7303166766    info@trufrost.com  
**[www.trufrost.com](http://www.trufrost.com)**