



USER MANUAL

**Table Top Tilt-head
Planetary Mixers: B+**

Welcome you made of choices our 7L foodstuff mixer. The mixer is our company developed with update technology. It can mixing dough, dumpling stuffing, circumrotates eggs and cream mixing. Constant-torque and infinitely variable speed technologies have been used in the mixer. You can select any rotating speed from 147 rpm to 917 rpm for different load, There is overload protect installation in the newest mixer. It is fine-looking, easy and safety operating. There are large application fields. Also, this mixer working is efficient and smoothly, It is an excellent helper to make cake and dough food in west food kitchen, bread-room, bar, restaurant and home etc.

1. Machine Illustration Diagram:

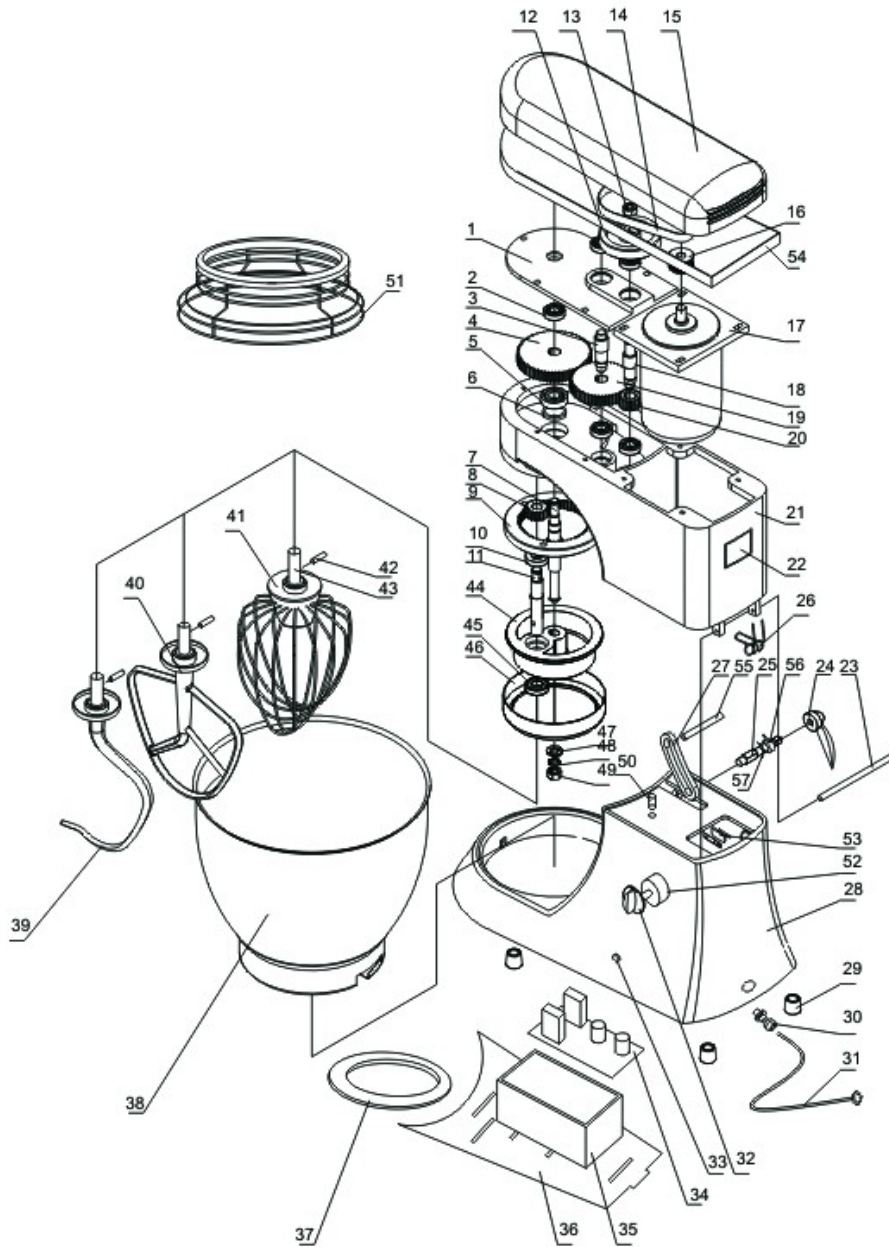

Drawing 1

II .Parts List:

Items	Parte Number	Description	Remark
1	CS10003-04	Root Plane	
2	CS10003-61	Bearing	Outside Buy
3	CS10003-11	Middle Axle	
4	CS10003-16	Large Gear	
5	GB278-80101	Bearing	Outside Buy
6	12x25x10HG/T2811	Seal I	Outside Buy
7	CS10003-19	Center Axle	
8	CS10003-17	Planet Gear	
9	CS10003-15	Inner Gear	
10	CS10003-23	Bearing	2
11	CS10003-14	Middle Axle	
12	CS10003-03	Large Belt Wheel	
13	GB6170-80-M8(左)	Nut	Outside Buy
14	120xL307	Belt	Outside Buy
15	CS10003-07	Top Cover	
16	CS10003-05	Small Belt Wheel	
17	CS10003-02	Motor	
18	CS10003-08	Axle Of Belt Wheel	
19	CS10003-12	Transfer Gear	
20	CS10003-10	Driving Gear	
21	CS10003-01	Body	
22	CS10003-63	Name Plate	
23	CS10003-43	Axle Pin	
24	CS10003-48	Handle	
25	CS10003-25	Support Pin I	
26	CS10003-06	Mechanical Spring I	Outside Buy
27	CS10003-24	Supper Plane	
28	CS10003-18	Base plane	
29	CS10003-21	Adjusting Screw	4

Items	Parte Number	Description	Remark
30	M16xΦ10X30	Electric Cable Plug	Outside Buy
31	GB5023.5-1997	Electric Wire	3x0.75mm ² ,L=1850mm
32		Button	Outside Buy
33		Switch	Outside Buy
34	CS10003-62	Circuit Plate	
35	CS10003-39	Electronic Box	
36	CS10003-22	Base Plate	
37	CS10003-27	Rubber Mat	
38	CS10003-36	Mixing Bowl	
39	CS10003-29	Hook Shape Mixing Agitator	Option
40	CS10003-30	Racket Shape Mixing	Option
41	CS10003-31	Net Shape Mixing Agitator	
42	CS10003-41	Pin	3
43	CS10003-46	Connecting Axle	3
44	CS10003-09	Main Axle Cover	
45	20x25x10HG/T2811	Seal	Outside Buy
46	CS10003-28	Adorning Cover	
47	GB95-85-Φ8	Cushion	Outside Buy
48	GB93-76-Φ8	Cushion	Outside Buy
49	GB6170-86-M8	Nut	Outside Buy
50	CS10003-53	Orientation Pin	
51	CS10003-60	Protection net	Option
52	CS10003-52	Speed Adjusting Button	Outside Buy
53	CS10003-53	Micro Switch	
54	CS10003-54	Decorative Stickers	
56	CS10003-55	Axle II	
56	CS10003-57	Mechanical Spring II	
57	CS10003-56	Nut	

Indication: Have no explain the spave parts' quantity in annotations fence equal to one

III. Function Features:

As the mixer has used infinitely variable speed and planetary gear technologies, so it has a large speed range. Easily operated. It can mixing dough, dumpling stuffing, circumrotates eggs and cream mixing. It is very good using in west food kitchen, bread-room, bar, restaurant and home.

IV. Assembly:

- 4.1 It is better putting the mixer on horizontal & stable plane, The best height of the plane is between 650mm–750mm. Please left 150mm–space distance at front and rear, Left 300mm at left and right.
- 4.2 The power must use a separating electronic socket with fuse device protecting. Rated. Voltage is 220V~ and Frequency is 50 Hz.
- 4.3 The electronic socket will have ground connection.
- 4.4 It is necessary to invite electricians to connect it to power.

V. Operation:

Operating parts is in drawing #2

5.1 Assemble and Dis-assemble

Shutting off the machine, turning by clockwise direction the handle to horizontal position by left hand. The head of ma-

chine will rise an angle automatically. Then release the handle, rising the head "A" to 45°, The head will be locked and the handle will leap back to vertical position.

Along a key of the mixer axle, insert the mixing agitator "D" to a hole in axle of mixer "C" lightly, turning left to "stop point" to assemble the mixing agitator. Reverse the process to dis-assemble the mixing agitator.

Rotating the handle to horizontal by left hand, The head will fall down, push the head down to lock. It is a working position. The handle will leap back to horizontal position.

The state of mixer head raising(Drawing 2)

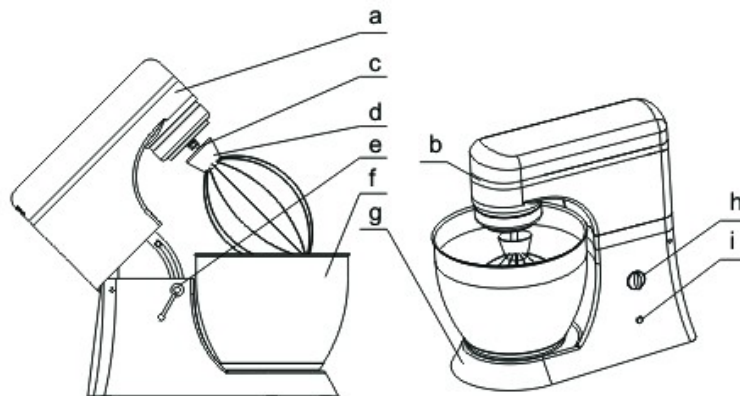

Drawing2

a. Head of mixer

c. Axle of mixing

d. Agitator of mixing

e. Handle

f. Bowl of mixing

g. Base Plane

h. Speed Adjusting

i. Switch

5.2 Making choice a suitable mixing agitator

There are three kinds of shape mixing agitator for choice.

5.2.1 Hook shape mixing agitator (No. 37) is for sticking and large things, such as dough etc.

5.2.2 Plane shape mixing agitator (No. 40) is for bulking things, such as meat dumpling stuffing etc.

5.2.3 Net shape mixing agitator (No. 41) is for unstuck or just a little stockless things. Such as eggs and creams.

Note: Don't select the mixing agitator wantonly. Otherwise the machine will not be working, even will be broken. Please according to the viscosity of mixing thing to make a choice.

5.3 How to Assembly and Dis-Assembly the Bowl.

Shutting off the machine, rising the head of the mixer "A". Hold tight stainless steel body with your two hands, follow the hour hand revolve to halt point, It should be fix.

Reversing the process to dis-assemble the bowl. Doing the step 5.1 again, pushing the head down to lock and Handle "e" will is at vertical position.

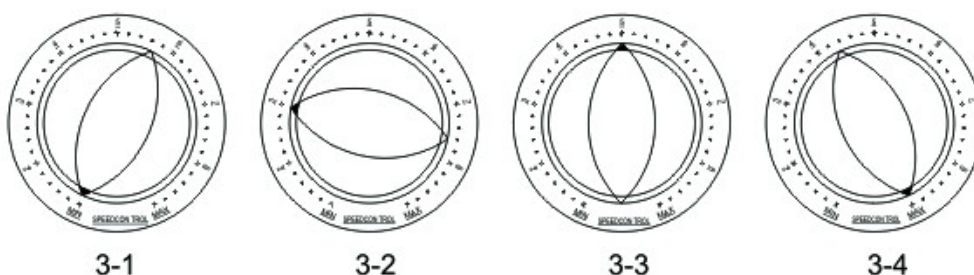

Drawing 3

5.4 The speed adjusting

Setting the speed button to "O" position (Drawing3-1), connection the electronic power, indicator light will be on, Starting the machine and clockwise direction turn the button to adjust the speed according to property of mixing thing and the mixing agitator. The speed will be increase while the button turn from left to right.

When the arrow indicate to top-left(drawing3-2), the mixer is low speed , it is good for dough.

When the arrow indicate to top of middle (drawing 3-3) that the mixer is middle speed, it is good for meat dumpling stuffing.

When the arrow indicate to top-right(drawing 3-4),the mixer is high speed , it is good for eggs.

This mixer is infinitely variable speed, user can choice best-speed for your job.

Rotary direction:(from shaft out):The rotary direction of main shaft cover(Item44) is clockwise(Red arrow),and rotary direction of mix shaft(item 11) is anticlockwise.

Note: Don't against the speed choice law above. Otherwise the machine working efficiency will be reduced. Sometimes even broken.Don't operating the machine over 10 Minute each time. The max. Flour weight to mix doesn't be over 500G. When Mix flour the limit gear is just gear1. Other's can be used gear 2. Limited

5.5 How to adjust the height of mixing agitator

Sometimes,The interval between bottom of mixing agitator to bowl is too close and sometimes it is too big, adjusting the height of mixing agitator is necessary . Detail is bellowing(drawing 4)

- a. Shutting off power first .
- b. Using a wrench to release the nut of mixing agitator.
- c. Adjust the interval.
- d. Tighten up the nut.



(Drawing 4)

5.6 Each job is finished, please return back the speed button to "O" position, then turning off the machine, cutting off the power.

VI. Safety Caution

- 6.1 Remove the machine, cutting the power first. When disassemble the mixing agitator, mixing bowl machine must be turn off.**
- 6.2 Don't using your wet fingers to operate the machine.**
- 6.3 Don't water the machine, don't put it in water.**
- 6.4 If any parts are broken or it is under un-normal condition must stop the machine, waiting to fix by technician.**
- 6.5 Don't put fingers in bowl, while it is working.**
- 6.6 Under age persons please keep away from the machine.**
- 6.7 When it is working or the head is raising, the handle "e" must be at vertical position.**
- 6.8 When the head is raising, don't put any fingers on link parts between head and stand of machine for injury.**
- 6.9 There is a ground point (Mark ⊕) in back of stands please keep them in original position after each maintenance.**

VII. Maintenance:

- 7.1 It is food machine, so all parts that contact with food has to remove and wash clear every day after working. Don't use cleaning pharmaceutical that may be injury persons.**
- 7.2 Don't turn on if there is nothing in bowl.**
- 7.3 When mixing agitator beat bowl, stop working immediately, and correct the space or change the agitator or bowl if necessary.**
- 7.4 please contact with supplier for technicians to maintain the machine.**

VIII. Trouble and Solution:

Trouble	Reason	Solution
Turn on, But don't working	<ol style="list-style-type: none">1. No power2. The speed button is not on "O" position	<ol style="list-style-type: none">1. Check the power plug and socket.2. Turns the button to "O" then start the machine.
Temperature of motor is increase & Speed is decrease	<ol style="list-style-type: none">1. Voltage is too lower.2. Load is too large.3. Mixing head is not suitable.4. Belt is wear out.	<ol style="list-style-type: none">1. Check the electronic Voltage.2. Reduce quantity of mixing (table 2)3. Choice suitable agitator.4. Change a new belt.
Suddenly stop while working	<ol style="list-style-type: none">1. Load is too large.2. Voltage undulate too large.3. Fuse is broken.4. Continue working time is too long.	<ol style="list-style-type: none">1. Reduce quantity of mixing (table 2).2. Check the voltage.3. Change a new fuse.4. Waiting a few minutes then re-start again.
Speed button is out of order	<ol style="list-style-type: none">1. The speed button is loose.2. The button is broken after long time work.	<ol style="list-style-type: none">1. Tighten up the screw of speed button.2. Make a Call for maintenance.
Mixing head beat the barrel	<p>The head position is correct.</p>	<p>According to the item 5.5 to adjust.</p>

Note: Please changes the carbon brush of electronic motor when it stops working for a long time.

VIII. Trouble and Solution:

Trouble	Reason	Solution
----------------	---------------	-----------------

IX. Technical Specification:

Description	Unit	Parameter
Volume of Mixing barrel	L	7.5
Speed of mixing mandrel	r/min	Revolution:40-250 Rotation:147-917
Rated voltage	V	220/230/240/110~
Rated Frequency	Hz	50/60
Input Power	W	325
Electric Current	A	1.5/3
Max. Eggs Weight	G	500
Max. Dough Mixing	G	500(Dry flour)
Working Environment		Indoor
Net Weight	Kg	16
Dimension	mm	400x250x410

X. Electronic Drawing:

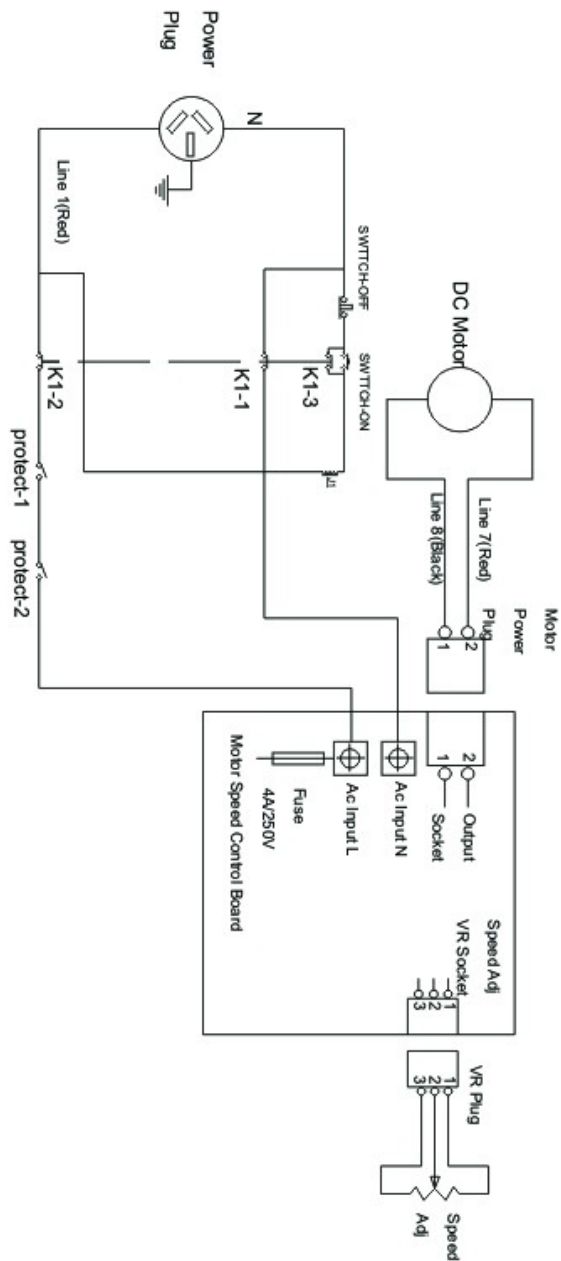

Electronic Drawing

Marketed in India by:

TRUFROST COOLING PRIVATE LIMITED

1215, 12th Floor, Tower B, Emaar Digital Greens, Golf Course Extn. Road,

Sector 61, Gurugram – 122102

T. +91-124- 4246560 info@trufrost.com

www.trufrost.com