

TRUFROST & BUTLER

The science behind
successful coffee shops





Successful cafés go beyond good coffee to create a perfect complement of confectionery and savouries that help create a winning formula. The lifeline behind a careful menu selection is often a range of equipment that is not just dependable and energy efficient but also aesthetically appealing. Presented here is a bouquet of products from Butler and Trufrost that perform tirelessly and help your cash registers moving.





CONTENTS

- Traditional Coffee Machines **6**
- Fully Automatic Coffee Machines **19**
- Milk Chillers & Cup Warmers **21**
- Coffee Beans Grinders **23**
- Coffee Accessories **25**
- Display Cases for Confectionery **30**
- Commercial Microwave Ovens **39**
- Ventless High Speed Ovens **41**
- Modular Bakery Equipment **44**
- Electric Convection Oven **48**
- Pizza Stone Ovens **51**
- Contract Grills **53**
- Fryers **56**
- Waffle Bakers **60**
- Chocolate Melter **61**
- Commercial Blenders **63**
- Drink Mixer **64**
- Professional Refrigeration **65**
- Ice Machines **66**
- Stainless Steel Furniture **67**

The best of Italian coffee

Coffee connoisseurs and many coffee lovers still fall back on traditional coffee machines for a real coffee experience. We offer traditional coffee machines from premium Italian names like Victoria Arduino, La Cimbali and Elektra that reflect the finest tradition of Italian espresso for both – popular as well as speciality cafes.

Victoria Arduino

ELEKTRA
ITALIAN ESPRESSO COFFEE MACHINES SINCE 1947

LA-CIMBALI

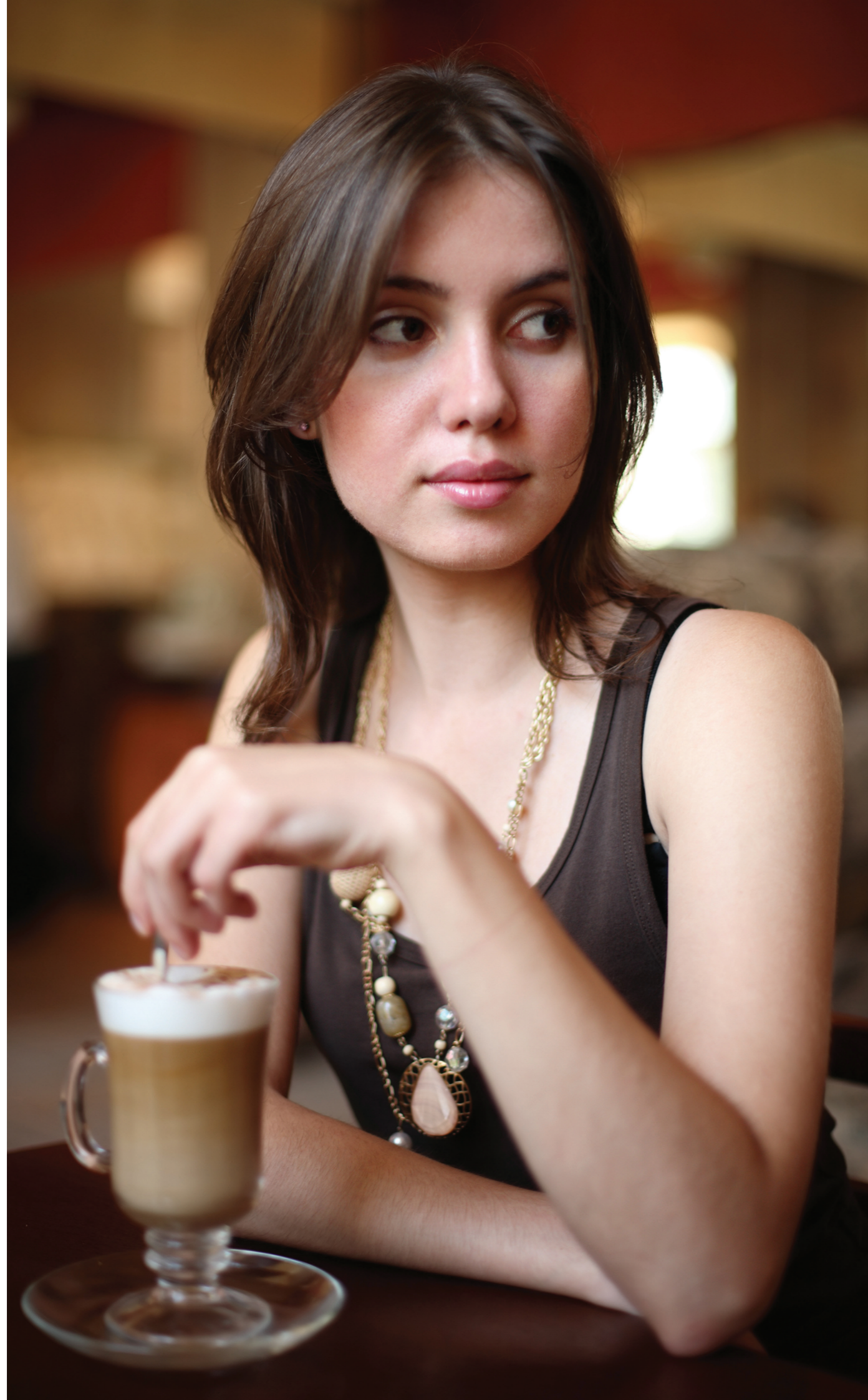

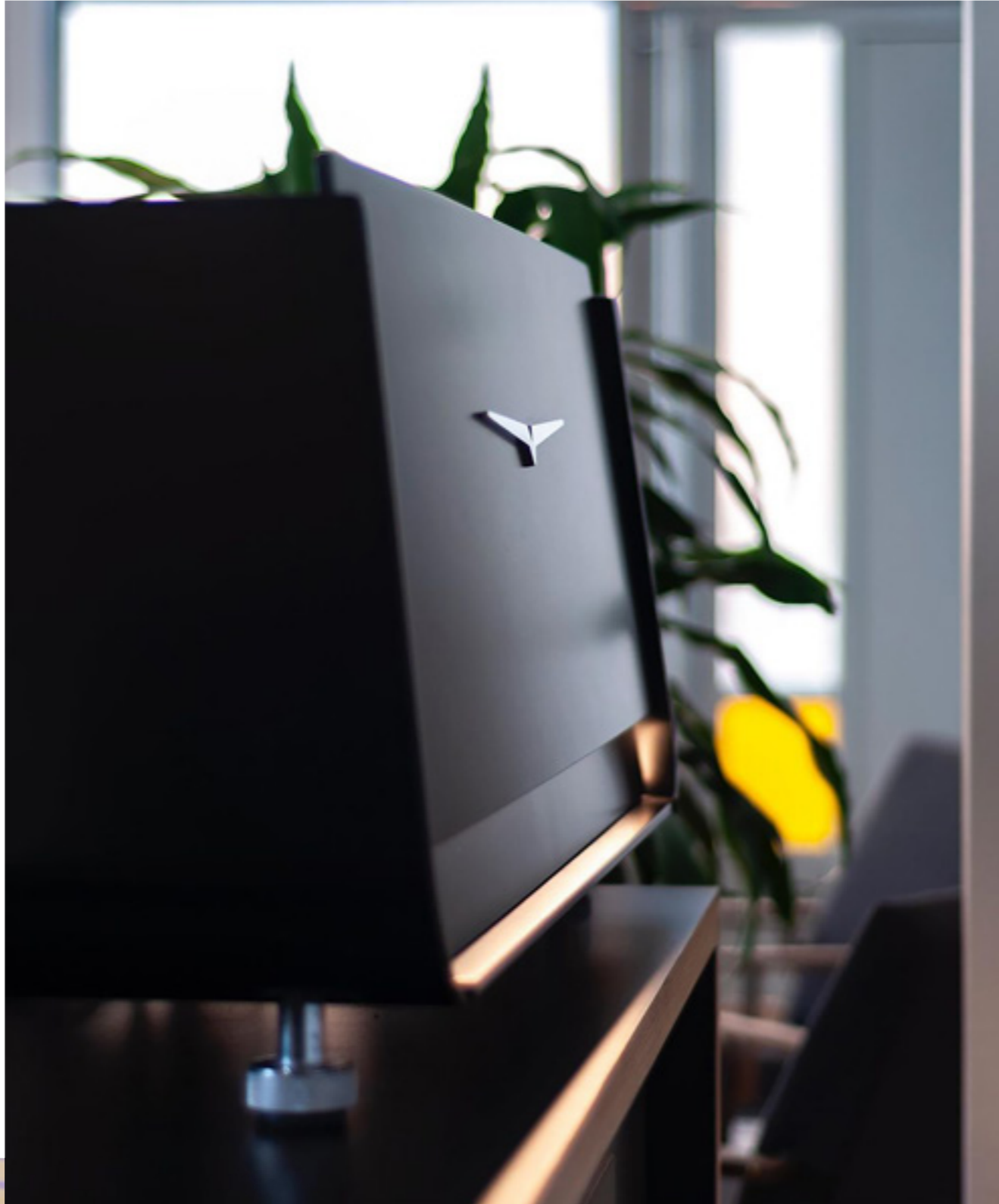

Victoria Arduino

INSPIRED BY YOUR PASSION.

Trufrost & Butler now brings Victoria Arduino coffee machines - the iconic brand behind the champs at the World Barista Championship- to India.

This marks the beginning of a new era for Indian speciality coffee and the pursuit of excellence across the coffee value chain - one inspired by your passion and your precision.

With this partnership, we reaffirm our commitment to India's rapidly growing coffee community by empowering cafés, baristas, and roasters with world-class equipment that delivers on consistency, performance, and design, backed by a strong support infrastructure.

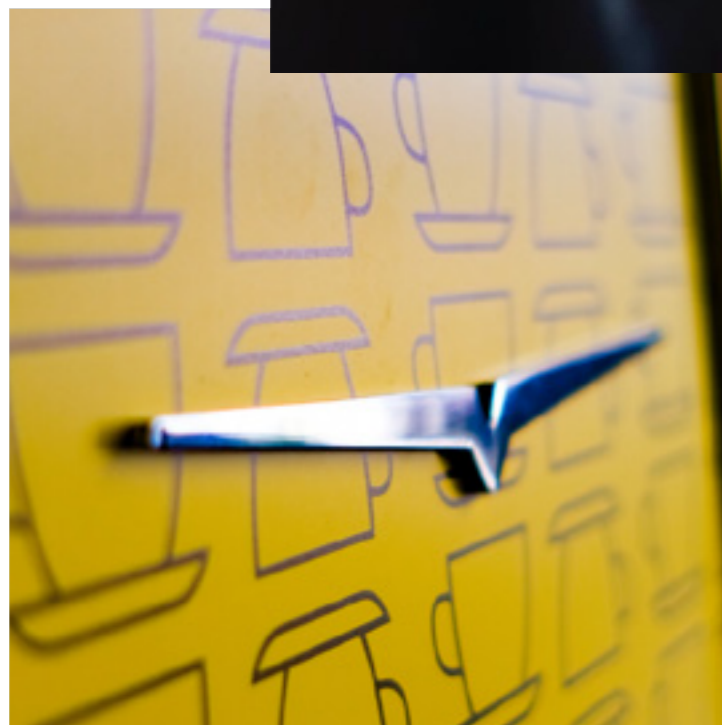

BLACK EAGLE MAVERICK



INNOVATION INSPIRES GENIUS

Black Eagle Maverick is the coffee machine for those who want to express the most of their potential, with a strong focus on sustainability and energy saving.

Black Eagle Maverick is intelligent and sustainable, able to offer total control over temperature, infusion, steam and even the opportunity to instantaneously switch between different types of coffee.

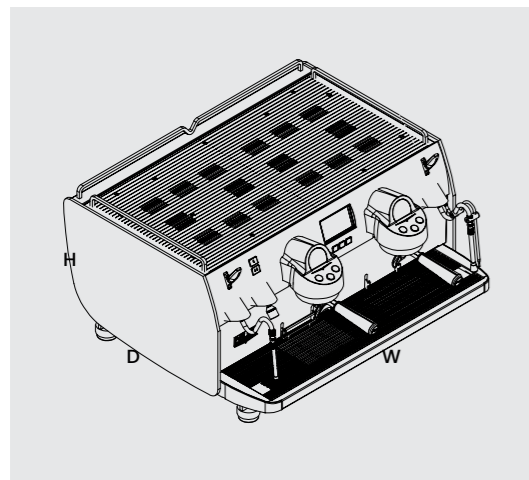

	2 Groups	3 Groups
Versions	Volumetric/gravimetric	Volumetric/gravimetric
Width (mm)	806	1056
Depth (mm)	682	682
Height (mm)	426	426
Group Height (mm)	100	100
Power (W)	6800	8600
Net Weight (Kg)	90	115
Insulated boiler (L)	8	8
Insulated coffee boiler (L)	0,6	0,6
Autopurge	standard	standard
Easycream	opt.	opt.

TECHNOLOGIES



T3 GENIUS

An evolution from T3 technology (temperature control and stability), able to offer the same precision and control, using 37% less energy. This important result was obtained by reducing the volume of the stainless steel boilers, by optimising the weight of the group, by increasing its reactivity and precision, by improving the electronics and by using waste energy from preheating the incoming water.

TERS

The patented TERS system (Temperature Energy Recovery System) makes it possible to use the waste water for preheating the incoming water, using a process of recycling and minimisation of waste with an **8% saving** on the total consumption of the machine.

PUREBREW TECHNOLOGY

PureBrew is the technology that, along with the new patented of PureBrewCoffee, a filter coffee with unique characteristics, activated from the machine or the app with a simple switch.

GRAVITECH

A volumetric system for control and management of the coffee in the cup able to guarantee maximum consistency and repeatability of the result.

ADVANCED STEAM

A high quality dry steam delivery system at high pressure (2.1 bar) with the addition of two controls for splitting the steam between different-sized jugs.

APP

With the creation of recipes based on espresso or Pure Brew and on their sensorial profile, and with the visualisation of flow rate, the Black Eagle Maverick app is extremely simple to use and allows the barista to have total control over one or more Black Eagle Mavericks.

COLOURS

Accessories kit includes red eagle personalisation



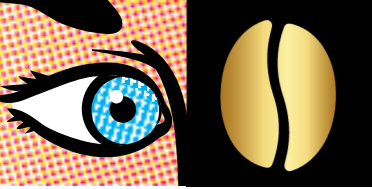

EJ EAGLE ONE



Product selected by
ADI Design Index 2020



FUTURE BEGINS

Eagle One is the coffee machine that was created to respond to the needs of the new generation of shops and chains where design, performance and sustainability make up the principal asset to provide a memorable experience to those who spend their days in the venue.

The machine represents the new way for an international clientele to spend time in the shop. People like this are, now more than ever, sensitive to a much broader concept of design that is created from experience and storytelling.

	2 Groups	3 Groups
Versions	Volumetric	Volumetric
Width (mm)	758	988
Depth (mm)	576	576
Height (mm)	437	437
Group Height (mm)	105	105
Power (W)	5000	6500
Net Weight (Kg)	68.5	84
Insulated boiler (L)	7	7
Insulated coffee boiler (L)	0,14	0,14
Autopurge	standard	standard
Easycream	opt.	opt.

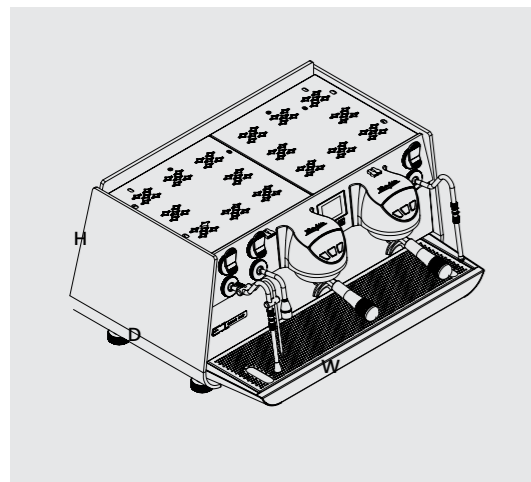

TECHNOLOGIES



NEO TECHNOLOGY

New Engine Optimization is an exclusive technology that enables high performance and improves energy efficiency. All the barista has to do is set the temperature from the display. The NEO motor uses the instantaneous heating technology that requires smaller volumes and boilers because only the water that is needed is heated.

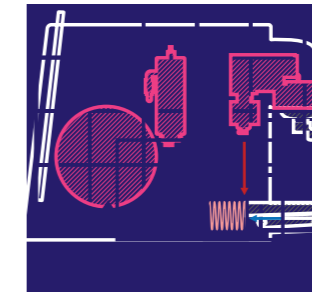

T.E.R.S.

The patented TERS system (Temperature Energy Recovery System) uses the waste water to pre-heat the incoming water, applying recycling and waste minimisation logic, with a saving of 8% on the total consumption of the machine.



EASYCREAM optional

The technological solution to obtain, every time, the same milk cream, simply and quickly. Easycream technology has a double wand that creams the milk and stops automatically as soon as the pre-set levels of temperature and milk cream have been reached. This is an extremely useful solution for speeding up the preparation of milk-based drinks, without loss of quality (optional).



VIS

VIS-Virtual Intelligent Scale is a Victoria Arduino technology developed to digitally estimate the right dose in the cup using an algorithm calculation. VIS brings improved workflow and the certainty of a great extraction making Eagle One an even better performing and smarter system.

COLOURS



Black



Stainless steel



White



Wood

EAGLE TEMPO

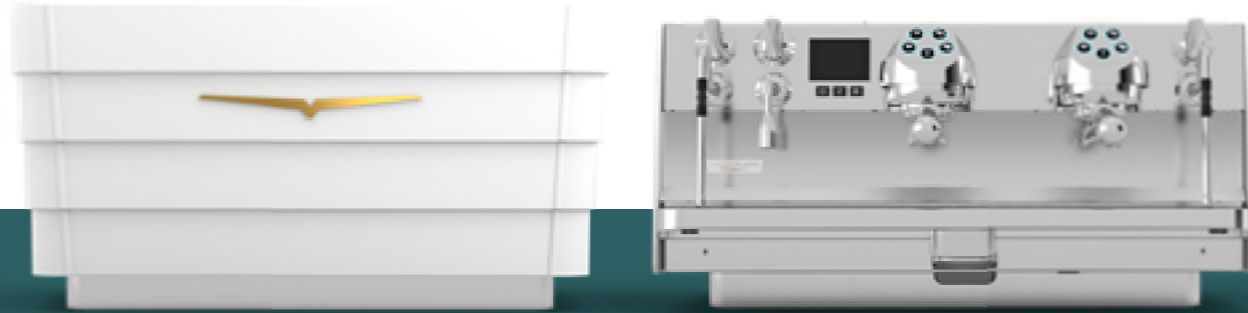

POETRY IN MOTION

Eagle Tempo is the professional espresso coffee machine specially designed for cafés, restaurants, roasteries, chains, pastry shops and bakeries. The new coffee machine combines the iconic brand, the elegant and distinctive design that is so characteristic of the Victoria Arduino range and high productivity performance.

Victoria Arduino thus strengthens its range with a product that has recognisable design and high productive capacity, incorporating technology that enables the business to be managed whilst saving energy and reducing waste.

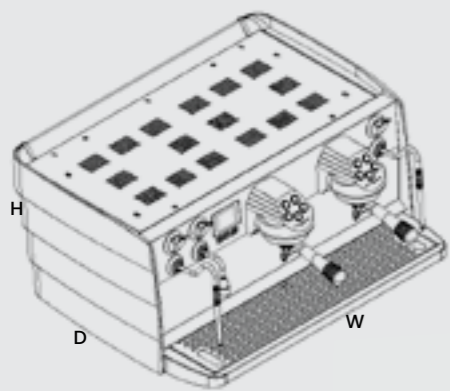

Versions	2 Groups		3 Groups	
	NEO	Single Boiler	NEO	Single Boiler
Width (mm)	825	825	825	825
Depth (mm)	650	650	650	650
Height (mm)	416	416	416	416
Low or High groups	-	-	-	-
Power (W)	6000	4700	7400	5200
Net Weight (Kg)	62	62	73	73
Insulated boiler (L)	8	11	8	17
Insulated coffee boiler (L)	0,14	-	0,14	-
Autopurge	opt.	opt.	opt.	opt.
Easycream	opt.	opt.	opt.	opt.

TECHNOLOGIES



NEO TECHNOLOGY

New Engine Optimization is an exclusive technology that enables high performance and improves energy efficiency. All the barista has to do is set the temperature from the display. The NEO motor uses the instantaneous heating technology that requires smaller volumes and boilers because only the water that is needed is heated.

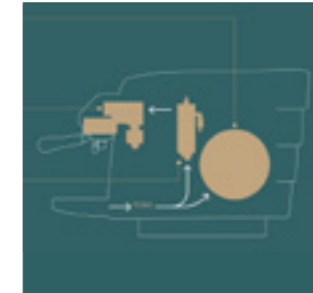

T.E.R.S.

The patented TERS system (Temperature Energy Recovery System) uses the waste water to pre-heat the incoming water, applying recycling and waste minimisation logic, with a saving of 8% on the total consumption of the machine.

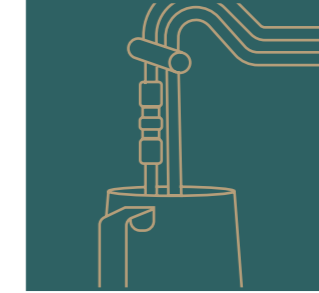

EASYCREAM optional

The technological solution to obtain, every time, the same milk cream, simply and quickly. Barista can create and set up to 9 milk/plant based drinks recipes, select them directly from the display home page and then pull the lever for the automatic steaming. The Easycream technology offers two different display modes (milk/coffee menu) to speedup the workflow.



HIGH PRODUCTION

The group with 5 pre-programmed buttons enables faster production and speeds up the workflow. The insulated stainless-steel boiler has an internal pressure of 2.1 bars that, working with the Steam-by-Wire electronic steam control, enable the dispensing of dry steam for a better drink quality and faster preparation.

COLOURS



Black



Stainless steel



Heritage



White

E1 PRIMA PRO

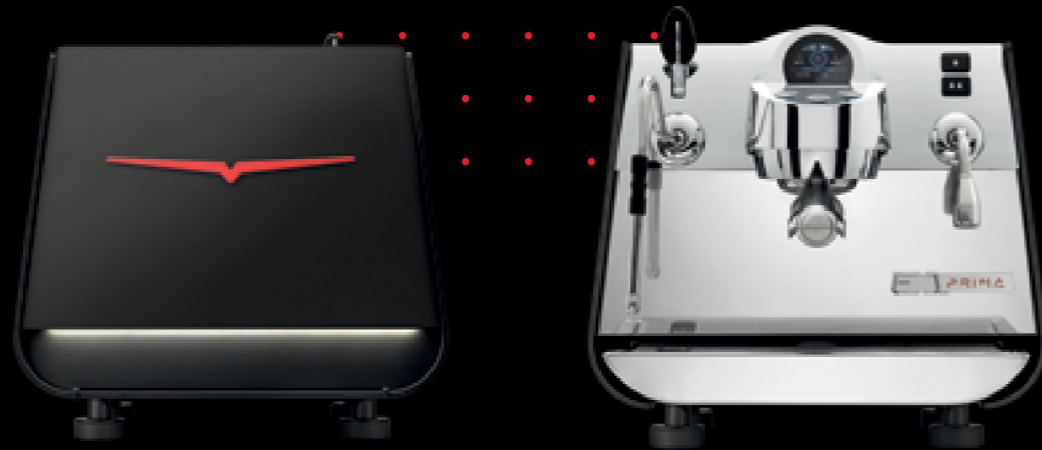

ALONGSIDE PIONEERS

E1 Prima PRO is the single group professional espresso machine for coffee specialists, roasters, chefs and mixologists who want to reach unexplored summits of quality, discover new boundaries of taste to savour the thrill of going where no one has gone before. The E1 Prima PRO is the most powerful single group Victoria Arduino has ever made. All standards are challenged and exceeded. This affects performance, control, flexibility of extraction, lightness and compactness.

1 Group

Width (mm)	410
Depth (mm)	510
Height (mm)	380
Group Height (mm)	95
Power (W)	Min 2000 / max 3100
Net Weight (Kg)	38
Insulated boiler (L)	1,8
Insulated coffee boiler (L)	0,6
T3 genius	Standard
Pure Brew Technology	Standard
PB tech	Standard
Autopurge	Standard
Easycream	Opt.

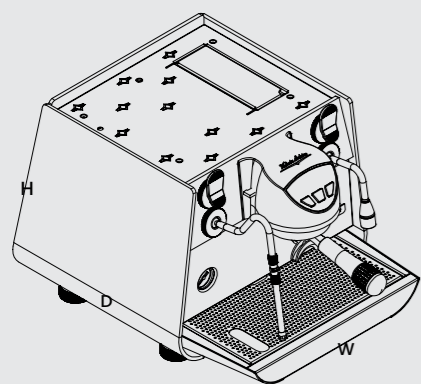

TECHNOLOGIES

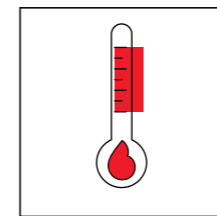

T3 GENIUS

Guarantees temperature control of the steam boiler, the coffee boiler and the group for maximum precision in the cup. The E1 Prima PRO Brew Temperature Reproducibility has obtained optimal results with perfect positioning within the range laid down by the World Coffee Events.

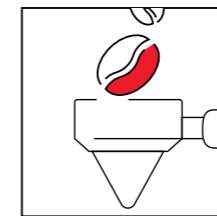

PURE BREW TECHNOLOGY

It's an innovative extraction method that is applied to espresso and to the extraction of a new drink without using pressure. Pure Brew pens to baristas a world of different recipes: from espresso to Pure Brew Coffee up to the extraction of tea and infusions to obtain perfect ingredients for mixing in cocktails and mocktails.

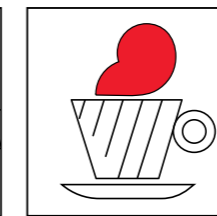

ADVANCED STEAM BY WIRE

A high quality drysteam delivery system at high pressure (2.1 bar) with the addition of two controls for splitting the steam between different sized jugs.

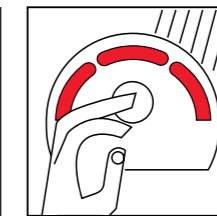

TOUCHSCREEN DISPLAY

The new 2.1" touchscreen display was designed to provide all information about the extraction, to be easy to read and to speed up every step of control and choice of setting.

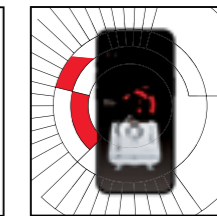

VICTORIA ARDUINO E1 PRIMA APP

Just connect the Victoria Arduino E1 Prima app to the coffee machine and the system immediately recognises the model being used to offer a navigating experience and uniquely easy recipe setting. From the app user scan create different recipes espresso, PureBrew and milk based and share them on the app 'Cloud recipe' section.

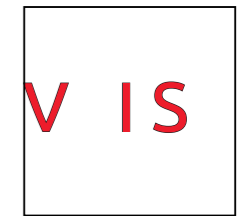

VIS

VIS technology digitally estimates the right dose in the cup through algorithmic calculation. VIS brings improved workflow and the certainty of a great extraction making E1 Prima PRO an even better performing and smarter system.

COLOURS



White



Stainless steel



Black

EXCLUSIVE COLOURS



Bold Black



Racing Red

E1 PRIMA EXP



HELLO! LIFESTYLE EXPLORERS

E1 Prima EXP is the machine dedicated to those who love exploring different tastes through the research of quality ingredients and who treasure discovering and creating new drinks without sacrificing the beauty of a unique and contemporary object. Eagle One Prima EXP not only prepares many espresso and latte drinks but incorporates the new extraction method to create our signature drink, Pure Brew.

1 Group

Versions	Volumetric
Width (mm)	410
Depth (mm)	510
Height (mm)	380
Group Height (mm)	95
Power (W)	min 1800 / max 2600
Net Weight (Kg)	37
Insulated boiler (L)	1,5
Insulated coffee boiler (L)	0,14
NEO Technology	Standard
Pure Brew Technology	Standard
Autopurge	Standard
Easycream	Opt.

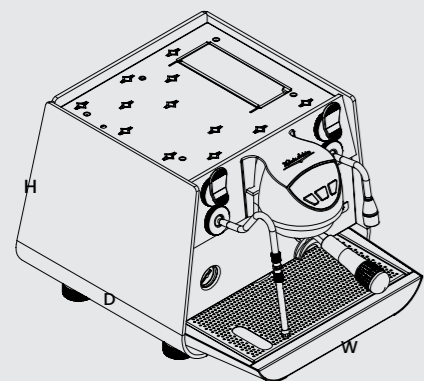

TECHNOLOGIES

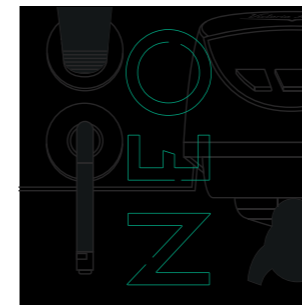

NEO TECHNOLOGY

New Engine Optimization is an exclusive technology that enables high performance and improves energy efficiency. All the barista has to do is set the temperature from the display. The NEO motor uses the instantaneous heating technology that requires smaller volumes and boilers because only the water that is needed is heated.

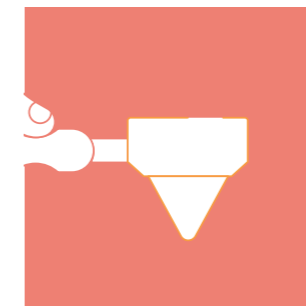

PURE BREW TECHNOLOGY

PureBrew technology, along with the new patented double-wall conical filter, provides the enjoyment of PureBrewCoffee, a filter coffee with unique characteristics, activated from the machine with a simple switch. Thanks to Pure Brew technology coffee lovers and baristas can extract a high-quality filter coffee or tea in less than three minutes and with a consistent result.

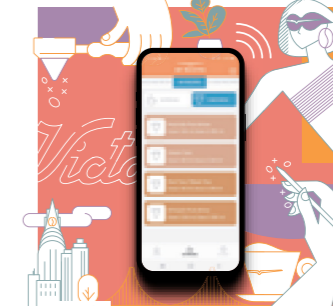

VICTORIA ARDUINO E1 PRIMA APP

Just connect the Victoria Arduino E1 Prima app to the coffee machine and the system immediately recognises the model being used to offer a navigating experience and uniquely easy recipe setting. From the app users can create different recipes espresso, PureBrew and latte based and share them on the app 'Cloud recipe' section.



EASYCREAM

The technological solution to obtain, every time, the same milk cream, simply and quickly. Easycream technology has a double wand that creams the milk and stops automatically as soon as the pre-set levels of temperature and milk cream have been reached. This is an extremely useful solution for speeding up the preparation of milk-based drinks, without loss of quality.

COLOURS



White



Stainless steel



Black

EXCLUSIVE COLOURS



Blue Pearl



Sparkling Coral



Metallic Lavander



Roman Coin

M200

La Cimbali introduces its new flagship, a true design icon created to stand out in any space. Every angle is designed to be seen, with no hidden sides. It combines futuristic style, solid engineering, and advanced technology with smart, intuitive ergonomics. Built for those who are passionate about great coffee and for the baristas shaping the future, today.



Technical Specifications

M200			
	Two Group	Three Group	Four Group
L	887 mm	1087 mm	1287 mm
L1	859 mm	1059 mm	1259 mm
L2	740 mm	940 mm	1140 mm
NET WEIGHT	70 Kg	92 Kg	110 Kg
	380-415 V3N 50-60 Hz	380-415 V3N 50-60 Hz	380-415 V3N 50-60 Hz
ELECTRICALS	220-240 V3 50-60 Hz	220-240 V3 50-60 Hz	220-240 V3 50-60 Hz
	220-240 V 50-60 Hz	220-240 V 50-60 Hz	220-240 V 50-60 Hz
POWER	6,2-7,4 kW	7,5-8,8 kW	8,8-10,4 kW
HYDRAULIC CONNECTION	ø 3/8 gas	ø 3/8 gas	ø 3/8 gas
HYDRAULIC FEEDING PRESSURE	1 ÷ 6 bar (0.6 MPa)	1 ÷ 6 bar (0.6 MPa)	1 ÷ 6 bar (0.6 MPa)
COFFEE BOILER CAPACITY	0,6 L	0,6 L	0,6 L
HOT WATER AND STEAM BOILER CAPACITY	7 L	7 L	7 L
AVAILABLE FINISHES	glossy white, matt black, polished aluminium (only M200 PROFILE)		

M23UP

This is yet another elegant, versatile commercial coffee machine from La Cimbali that is easy to use and maintain. Ergonomic and robust, the M23UP is made of steel. Its fixed-nozzle thermosyphon system is reliable and guarantees top performance, for excellent results in the cup every time. Lights on the coffee group (optional) can be used to illuminate the work space. This is specially designed for commercial usage like coffee shops, restaurants, QSRs and retail outlets.



M23UP			
	DT2 C2	DT2 / C2 TALL CUP	DT2 / C2 TALL CUP
Multidirectional steam wands	2	2	2
Hot water wand	1	1	1
Boiler Capacity (L)	11	11	17.5
Power (W)	4100-4800	4100-4800	5900-7000
Electricals	220-240V /50Hz/ 1Ph	220-240V /50Hz/ 1Ph	220-240V /50Hz/ 1Ph
Dimensions (WxDxH) mm	820 x 518 x 552	820 x 518 x 552	1020 x 518 x 552
Weight (Kg)	63	63	78



LA-CIMBALI

Express Yourself



ELEKTRA



Eklipto

Simplicity,
Styled

EKLIPTO offers a perfect balance of simplicity, style and flexibility.

Experience the perfect fusion of tradition and trend with the Elektra Eklipto—delivering iconic Italian craftsmanship wrapped in a bold, undeniably cool aesthetic



Simplicity

The Elektra Eklipto combines advanced performance with effortless simplicity, making it ideal for entry-level and mid-range coffee setups. With digital temperature control, electronic pre-infusion, dual steam wands, intuitive programming, and automatic cleaning, it ensures smooth and efficient operation.

More than an espresso machine, Eklipto is a statement piece. Its clean lines, bold geometry, mirrored stainless steel body, and warm wood handles create a refined balance of modern elegance and Italian craftsmanship, delivering both performance and style in every cup.





One Machine. Every Coffee.

The Elektra Eklipto is engineered for unparalleled versatility, making it the ideal choice for any coffee, from exquisite specialty beans to your daily blend.



Technical Specifications

	1GR	2GR	3GR
Body material		Stainless steel or painted metal	
Voltage		220-240V 50Hz /60Hz	
Power	1850 W	3150 W	4350 W
Weight	42 Kg	58 Kg	73 Kg
Dimensions	560x588x470	860x588x470	1070x588x470
Heating system	51 Single boiler heat exchanger	111 Single boiler heat exchanger	141 Single boiler heat exchanger
PIO Control		Included	
Coffee pump	50l/h Rotative	100l/h rotative	200l/h rotative
Pressure gauge		Duoble manometer, pump and steam pressure	
Brew head		E6 I automatic professional brewing group	
Pre-Infusion		Adjustable for each button	
Automatic cleaning		Included	
Steam Wand		Stainless steel cold touch with wood finishing	
Hot water wand		Stainless steel with wood finishing	
Hot water wand		5	
Display		Included	
LED		Included	
Boiler insualtion		Optional	
Electical cup warmer		Optional	

Specifications are subject to change without prior notice due to continuous product development

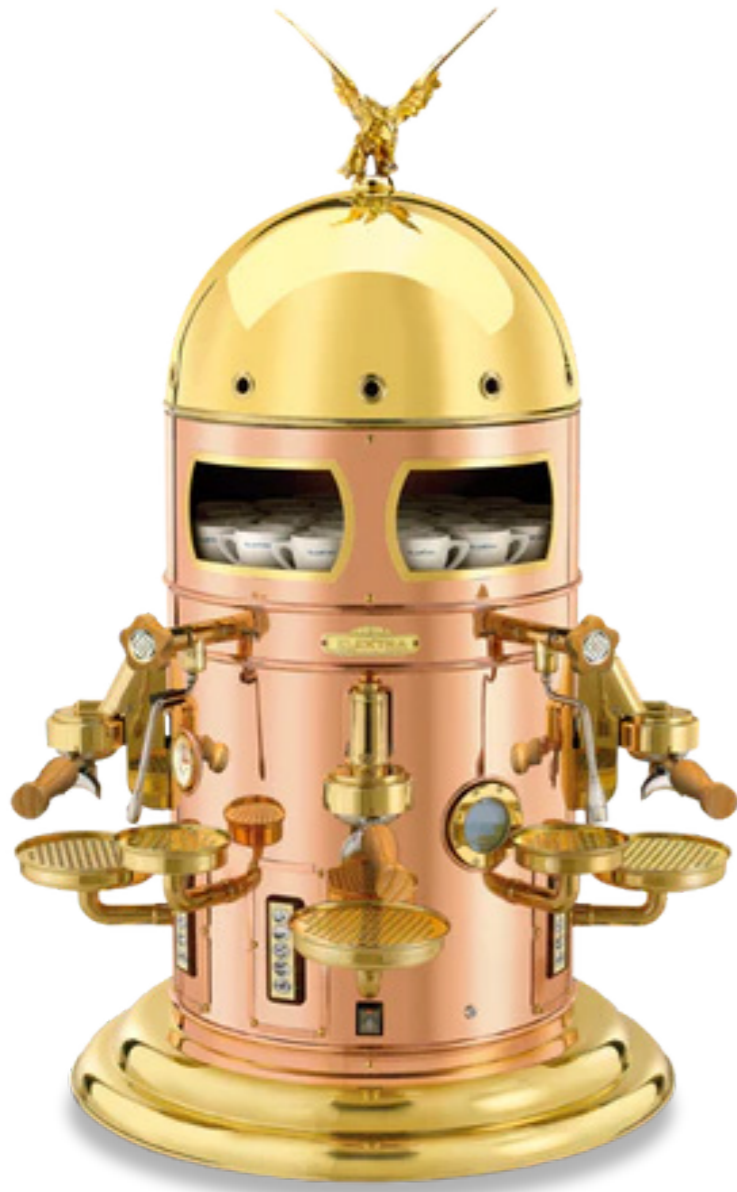

Elektra Belle Epoque

This stunning coffee machine from Elektra of Italy is available in India exclusively through Trufrost & Butler. It features a unique vertical design. The Belle Epoque (also known as the coffee machine with the eagle) exemplifies exceptional elegance, where beauty harmonises with functionality and reliability. Modelled with retro charm, it possesses a distinct character that enhances the choreography of refined and elegant spaces. This stylish coffee machine is a limited-edition offering for the most discerning buyers and coffee shops seeking to distinguish themselves from the crowd.



Technical Specifications

Model	Belle Epoque
Brand	Elektra
Rated input power	3700 W
Electricals	220V/50Hz
Boiler Capacity	9L
Height mm	890+190 mm
Diameter	Ø570 mm
Net Weight	53 Kg

Voltage: 220-240V/50Hz

Specifications are subject to change without prior notice

The technical features that characterize this machine are:

- ◆ Electronically programmable temperature for coffee and steam boilers
- ◆ Automatic coffee dispensing buttons with four programmable doses and a manual one
- ◆ Integrated 200l/m rotary pump with super silent technology
- ◆ Patented, inspectable heat exchangers
- ◆ Lead-free brass (OT57) dispensing units featuring high thermal properties
- ◆ Multidirectional steam wand and hot water tap
- ◆ Anti-torsion metal frame
- ◆ Automatic, independent group cleaning cycle
- ◆ ECO mode for saving energy



Make great coffee
with just a touch



Bean to cup coffee machines for every need



200 cups/day

Coffee Bar Pro-T



150 cups/day

Coffee Break Pro-T



150 cups/day

Coffee Break Premia



100 cups/day

Italia TurboSteam Pro



70 cups/day

Milano TurboSteam



Technical Specifications - Fully Automatic Coffee Machines



Items	Coffee Bar Pro-T	Coffee Break Pro-T	Coffee Break Premia	Italia TurboSteam Pro	Milano TurboSteam
Brand	Dr. Coffee	Dr. Coffee	Butler	Butler	Butler
Advised daily output	200 cups	150 cups	150 cups	100 cups	70 cups
Rated input power	2900 W	2900 W	3100 W	1500-1700 W	1550 W
Electricals	220V/50Hz	220V/50Hz	220V/50Hz	220V/50Hz	220V/50Hz
Pump Pressure	19 Bar (Double Boiler System)	19 Bar (2 Thermo blocks)		19 Bar (2 Thermo blocks)	19 Bar (2 Thermo blocks)
Water Tank Capacity	-	2L (Small) + 8L (Big)	2L (Small) + 6L (Big)	8 Litres + Tap Water	2 Litres + Tap Water
Beans hopper capacity	1200g x 2	1200g	750g	1200g	500g
Powder hopper capacity (L)	1.2L x 1 / 1.0L x 1	-	-	-	-
Adjustable height of coffee spout	80-165mm	80-165mm	75-155mm	80-165mm	80-120mm
Ground coffee container capacity	70 portions	70 portions	50 portions	70 portions	20 portions
Drain water tray capacity	-	-	2 Litres	2 Litres	0.7 Litres
Machine Weight	26 kg	26 kg	20 kg	17 kg	14 kg
Dimensions (WxDXH)	340x545x620 mm	410x500x580 mm	340x559x578 mm	410x500x580 mm	300x490x440 mm

Specifications are subject to change without prior notice due to continuous product development



Milk Chillers

Refrigerated units from Trufrost with a real compressor in elegant black colour to go with your coffee machine. Frigo-Milk Premia preserve up to 8 (4+4) litres of milk. You can create the perfect light milk foam for trendy coffee creations by keeping the milk fresh and at a constant, cool temperature. It is taller and trendier with a digital temperature display on the door.



Frigo Milk Premia

Cup Warmers

The Butler electric cup warming units come in an all stainless steel construction. They have 2 cup warming shelves for preheating upto 72 cups for a real coffee experience. The special airflow ensures even heat distribution.



CW 2

Technical Specifications



Model	Capacity	Temperature Range	Refrigerant	Dimensions WxDxH (mm)	Internal Cavity WxDxH (mm)	Power
Frigo Milk Premia	9 Litres	1-10 °C	R600a	220x450x454	160x190x280	70 W
CW 2	-	60-85 °C	-	360x320x550	-	14 W

Voltage: 220-240V/50Hz

Specifications are subject to change without prior notice

4 steps to good coffee

- 1 Quality coffee beans
- 2 Freshly ground coffee powder
- 3 Good crema
- 4 Your favourite coffee



Manual and On-demand Coffee Beans Grinders

Butler Professional Coffee Grinders are built in an elegant combination of steel and black and are a perfect complement to your Traditional coffee machine. You can choose between an automatic grinder Ethos, manual grinder - Stride and Saga & Yoga on-demand doser-grinder that also has a digital display. Ethos grinds the beans by weight. They have single-bodied, hermetically sealed dosers that prevent aroma loss. The motor is equipped with a thermal protector.



Ethos



Saga



Yoga



Stride

*Available in white colour variant also.

Technical Specifications



Model	Hopper Capacity	Dispenser Capacity	Display	Burr Adjustment	RPM	Flat Burr	Dimensions W X D X H (mm)	Power	Weight
Ethos	1650 gms of beans	On demand by weight	5.0" Touch screen	Digital	800 - 2400 (Brushless DC Motor)	83mm titanium	230x290x550	800 W	11 Kg
Saga	1650 gms of beans	On demand	5.0" Touch screen	Digital	1360-2150 (Variable motor speed)	83mm titanium	290x380x700	680 W	13.5 Kg
Yoga	1650 gms of beans	On demand	4.3" Touch screen	Manual	1650	74mm titanium coating	230x400x600	550 W	13.5 Kg
Stride	1650 gms of beans	Manual	-	Manual	1360	64mm high-end metal	230x400x600	420 W	11 Kg

Voltage: 220-240V/50Hz

Specifications are subject to change without prior notice



Mythos



GRINDING
PERFECTION.
AGAIN.

TECHNOLOGIES

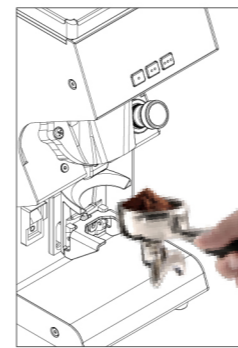

CLIMA PRO

The proactive grinding system that offers maximum consistency of dose throughout the whole working day. All the barista has to do is set the grinding temperature from the display and the system does the rest: the probe positioned in the grinding chamber monitors the temperature, whilst the Clima Pro algorithm activates or deactivates the heating or cooling systems to constantly maintain the pre-set parameters.

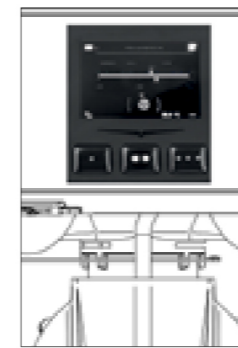

ELECTRONIC MONITORING OF GRIND SETTING

A solution that enables greater precision and grind regulation, but also an enormous time saving after cleaning: the system memorises the position and guides the barista to the grind setting.

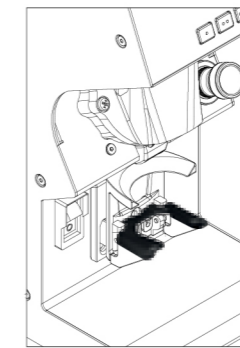

GRAVITECH

Technology with incorporated scales and with an easily-set algorithm for fast calibration and dosage, thanks to a predictive system that automatically monitors dose precision and grinding speed. Greater flexibility, waste reduction and maximum precision are the immediately noticeable advantages even before first use.

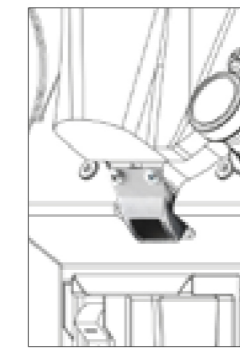

CLUMP CRUSHER

Guarantees perfect flow of ground coffee into the portafilter, thus notably reducing cleaning and maintenance times, thanks also to better accessibility.



DISPLAY TOUCHSCREEN

The barista has full control over the information and settings thanks to the touchscreen display with its adaptive logic and thus highlighting all the most important information for his/her work, in real time, whilst maintaining routine data in the background.

Mythos is the professional grinder that has been able, once again, to reach grinding perfection with important improvements from the points of view of user experience, grind control and design.

The official grinder of the World Barista Championship, Mythos defines a world of detail, but with a unique design, with the same passion and strong values to share with baristas, roasters and chains throughout the world once again to reach grinding perfection.

COLOURS & VERSIONS

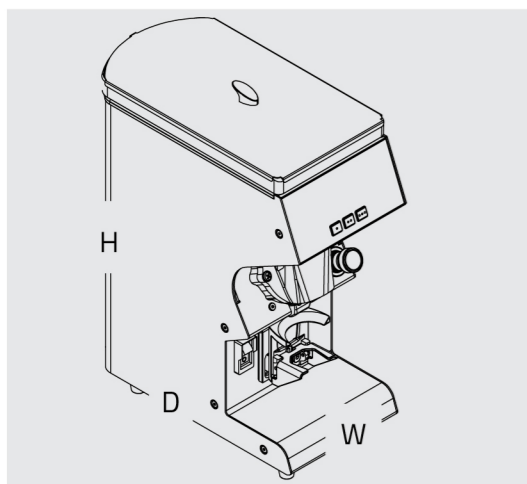

	MYONE	MY75
Width (mm)	195	195
Depth (mm)	395	395
Height (mm)	479	479
Bean hopper (Kg)	1,5	1,5
Burrs (mm)	75	75
Power	220 V / 600 W 110 V / 1200 W	220 V / 600 W 110 V / 1200 W
Net weight (Kg)	23,7	23,8
Dosage	Timed	Timed



Black



White



Myone Black

Coffee accessories



Milk Pitcher
(350ml, 600ml, 1L)

MP-4-1, MP-4-2, MP-4-3



Milk Pitcher
(350ml, 600ml, 1L)

MP-13-1



Milk Pitcher
(350ml, 600ml, 1L)

MP-22-1

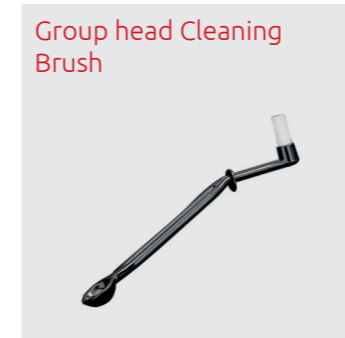

Group head Cleaning
Brush

BR-1



Coffee Grinder Cleaning
Brush

BR-4



Corner Tamping Mat Dual

CM-8



Coffee Tamber Seat

CM-7-2



Coffee Distributor
58mm

CD-15



Wooden Tamber 58mm
Beech Handle

TP-5

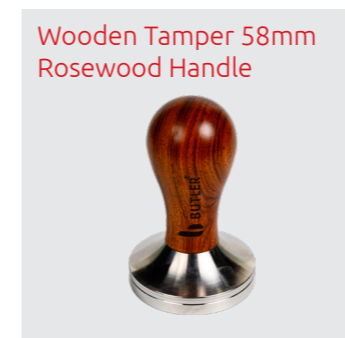

Wooden Tamber 58mm
Rosewood Handle

TP-6



Knock Box Chute with
Bottom Open

KB-2

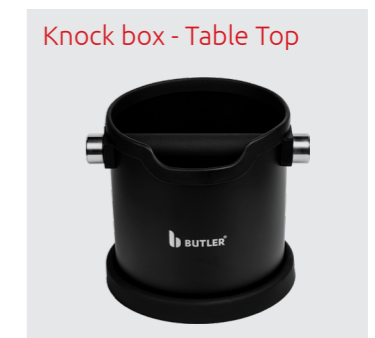

Knock box - Table Top

KB-6-2

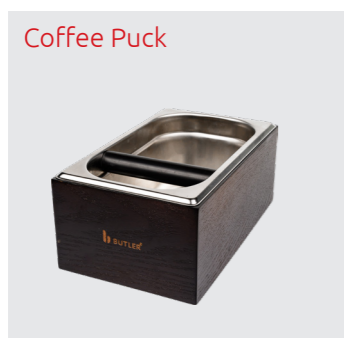

Coffee Puck

KB-13-2

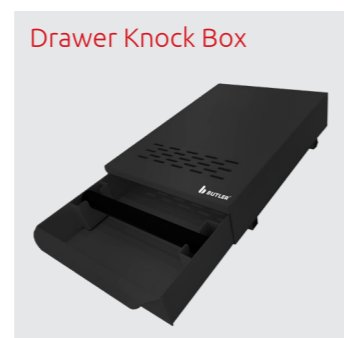

Drawer Knock Box

Knock out



Barista Cleaning Cloth

CMS-8-2

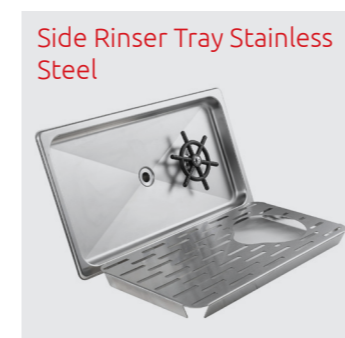

Side Rinsing Tray Stainless
Steel

CR-2

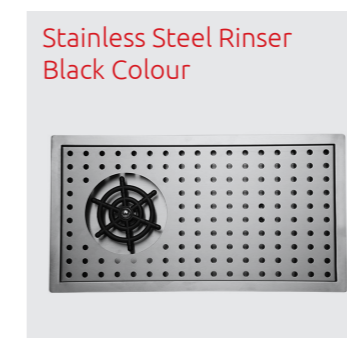

Stainless Steel Rinsing
Tray Black Colour

CR-10



Cleaning Tablets (1gm)

N10



Cleaning Tablets (2.3gm)

F23



Cleaning Tablets (1.5gm)

S15



MFC Powder Eco For Milk
System

MFC



Grinder Cleaner

GC2



Espresso Machine Cleaning
Powder

EC2



When coffee meets cake

Great coffee needs to be complemented with great food. But its best companions are often cakes, pastries, croissants and deli. When displayed intelligently and smartly, they can be the real show-stoppers, magnetising your customers, and prompting them to make choices that enhance your food as well as beverage business.





Give your desserts the stage they deserve

Invariably, the most interactive area in any store is an inviting display of confectionery and savouries. Trufrost has a whole array of stylish and contemporary confectionery showcases that would do any convenience store, supermarket, café and cake shop proud. For a supermarket application, these display cases perfectly complement the other food retail equipment to create a holistic customer experience.



Why Trufrost confectionery showcases are miles ahead?

Reduce Food Wastage:

If your showcase display looks anything like this, it's time for an upgrade to Trufrost. Our display cases feature advanced double-tempered, heated front glass for clear visibility and condensation-free hygiene. A reliable ventilated refrigeration system with auto-defrost ensures uniform cooling, keeping everything from traditional Bengali mithais to exotic cheesecakes; fresh for longer.

Aesthetics:

Designed with an elegant blend of black glass and stainless steel, Trufrost display cases are enhanced with contemporary LED lighting under each shelf, creating a premium, international-style ambience that elevates your product presentation.

Conventional Display



Trufrost Display



elegance in simplicity

The elegance of flat glass showcases has taken over the modern design due to its sheer simplicity and clean lines. This lends a more modern look to the overall ambience and has become quite popular in the recent times.





Flat Glass Showcases - Premia Series

The Premia series Flat Glass Showcases from Trufrost are specifically designed to captivate your customers. The side and front glass feature a chic, Italian-style black lacquer border, while the base is meticulously crafted from stainless steel with a black titanium finish to enhance the premium look of your store's ambience. These stunning showcases are fitted with advanced, double-tempered heated front glass that improves visibility and prevents the unhygienic condensation often found in conventional display cases.



CSF 44 Premia
WSF 44 Premia

Flat Glass Showcases - Max series

The Max Series Flat Glass Showcases from Trufrost are designed for customers seeking strong performance and premium styling at an attractive price point. With a sleek black glass finish, enhanced visibility, and reliable cooling, these showcases are ideal for presenting desserts, bakery items, and confectionery in a visually appealing and hygienic manner.

- ◆ Double-tempered, heated front glass to minimise condensation
- ◆ High-definition, vacuum-sealed toughened glass
- ◆ Ventilated refrigeration system with gentle fan cooling
- ◆ Auto-defrost for consistent performance
- ◆ 4-tier display: base + 3 adjustable, angled shelves
- ◆ LED lighting under each shelf
- ◆ Digital temperature controller with temperature display
- ◆ Black lacquered glass border with matching black painted metal base
- ◆ Sliding rear doors for easy product loading
- ◆ Castors for effortless mobility and cleaning
- ◆ Optional warm showcase available in matching size



CSF 44 Max



3 Plus 2 Combination Display Showcase

This fashionable new product with an international appeal from the house of Trufrost comes with 3 feet wide cold display for cakes and confectionery that has a front heated glass that keeps the condensation away. It has an adjacent 2 feet of open chilled display that gives a magical look to the store ambience. The twin model comes in an overall 1500mm width and has a provision for 3 shelves apart from the base platform.



3 Plus 2 Premia



Crystal Tower Premia

Designed to create a stunning 360° display for cakes, beverages and gourmet treats that instantly elevates your store appeal. Featuring panoramic glass with LED lighting, ventilated refrigeration, auto defrost and a premium black titanium finish for uniform cooling and visual impact.



Panoramic Chiller Showcase



Frozen Tower (Panoramic Ventilated Freezer Showcase)

Crafted to showcase gelato and frozen desserts with maximum visibility and uncompromising elegance. Equipped with panoramic heated glass, ventilated refrigeration and adjustable shelves for crystal-clear display and consistent freezing performance.



Panoramic Freezer Showcase

the fashion
statement

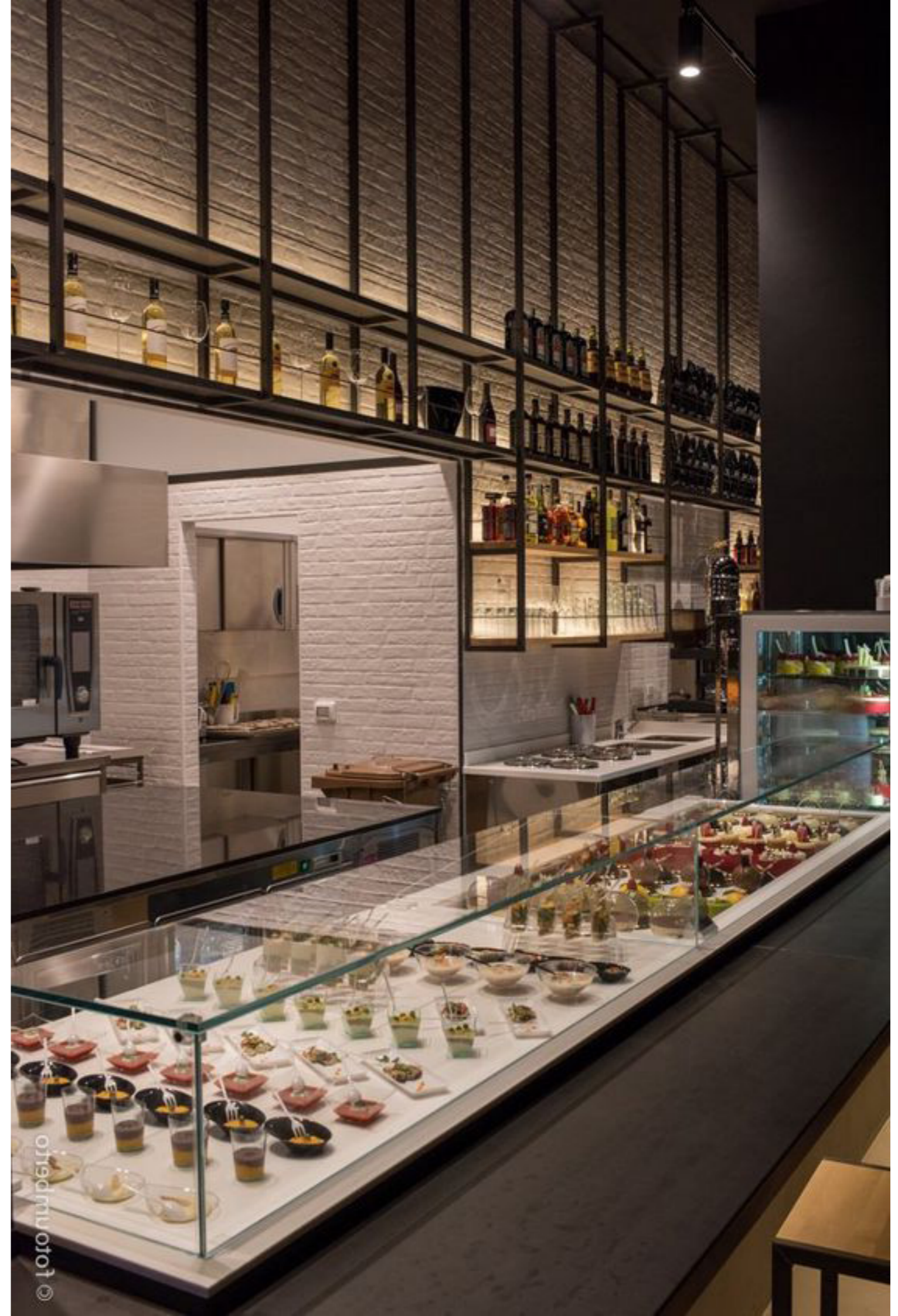

Diva

Inspired by the jewellery shop and high-end fashion boutiques, this jewellery box type display showcase from Trufrost is perfect for gorgeous creations especially, exotic pastries and chocolates. It has two refrigerated pull-out drawers at the rear and brilliant LED lighting to enhance the display. It also comes with an additional refrigerated storage underneath the drawers. You can place multiple units together to give a magical look to your store's ambience.



Diva 900 Premia
Diva 1200 Premia



Pull-out Drawers



Diva 42 Premia

over the counter



CTSR-23 Premia

Countertop Cold Displays

Suitable for showcasing and retailing Cakes, Pastries, Indian Desserts, Dairy Products, Cold Cuts, Sandwiches and Beverages. You can choose between two models that come in a dazzling combination of steel & glass, and fitted with a reliable, bottom mounted cooling system.



Baby Tower

Baby Tower

This newly launched stunning countertop cold display is suitable for showcasing and retailing Cakes, Pastries, Indian Desserts, Dairy Products, Cold Cuts, Sandwiches and Beverages. It comes in a dazzling combination of elegant black and glass, and is fitted with a reliable, bottom mounted cooling system.

display the warmth

Countertop Warm Displays

Suitable for showcasing and retailing a wide variety of appetizers and savouries like Samosas, Kachories, Patties, Wraps, Cutlets, Kathi Rolls and similar snacks. You can choose between 3 models that come in a dazzling combination of steel & glass. The model, CTW-4 is particularly suitable for displaying Halwas, Gulab Jamuns or similar Indian desserts that are served warm. FDW-3 is also suitable for displaying warm pizzas amongst other food items.



CTSW 23 Premia



CTW 4



FDW 3 x 660



Technical Specifications - Confectionery Showcases



Model	Product	No. of Layers		Dimensions W*D*H (mm)	Volume (Litres)	Temperature Range (°C)	Front Glass	Refrigerant	Power (Watts)
		No.	Description						
CSF 24 Max	Flat Glass 4 Layer Cake Showcase	4	Base + 3 shelves	600*660*1300	240	2~8	Heated	R 134a	410
CSF 44 Max	Flat Glass 4 Layer Cake Showcase	4	Base + 3 shelves	1200*660*1300	530	2~8	Heated	R 134a	480
CSF 24 Premia	Flat Glass 4 Layer Cake Showcase	4	Base + 3 shelves	600*700*1300	240	2~8	Heated	R 134a	410
CSF 34 Premia	Flat Glass 4 Layer Cake Showcase	4	Base + 3 shelves	900*700*1300	390	2~8	Heated	R 134a	450
CSF 44 Premia	Flat Glass 4 Layer Cake Showcase	4	Base + 3 shelves	1200*700*1300	550	2~8	Heated	R 134a	480
CSF 54 Premia	Flat Glass 4 Layer Cake Showcase	4	Base + 3 shelves	1500*700*1300	670	2~8	Heated	R 134a	450
CSF 34	Flat Glass 4 Layer Cake Showcase	4	Base + 3 shelves	900*730*1300	390	2~8	Heated	R 134a	450
CSF 44	Flat Glass 4 Layer Cake Showcase	4	Base + 3 shelves	1200*730*1300	530	2~8	Heated	R 134a	450
CSF 54	Flat Glass 4 Layer Cake Showcase	4	Base + 3 shelves	1500*730*1300	670	2~8	Heated	R 134a	450
CSF 45 Tall Premia	Flat Glass 5 Layer Cake Showcase	5	Base + 4 shelves	1200*740*1900	950	2~8	-	R290	995
WSF 44 Max	Flat Glass 4 Layer Warm Showcase	4	Base + 3 shelves	1200*660*1300	530	40-65	-	-	450
WSF 34 Premia	Flat Glass 4 Layer Warm Showcase	4	Base + 3 shelves	900*700*1300	400	40-65	-	-	450
WSF 44 Premia	Flat Glass 4 Layer Warm Showcase	4	Base + 3 shelves	1200*700*1300	530	40-65	-	-	450
WSF 54 Premia	Flat Glass 4 Layer Warm Showcase	4	Base + 3 shelves	1500*700*1300	670	40-65	-	-	450
WSF 44	Flat Glass 4 Layer Warm Showcase	4	Base + 3 shelves	1200*730*1300	530	40-65	-	-	450
WSF 54	Flat Glass 4 Layer Warm Showcase	4	Base + 3 shelves	1500*730*1300	670	40-65	-	-	450
3 Plus 2 Premia	3' Cake Showcase + 2' Open Showcase Chiller	4	Base + 3 shelves	1500*700*1300	480	2~8	Double Glass	R 290a	930
Crystal Tower Premia	4 Side Glass Panoramic Cake Showcase	5	Base + 4 shelves	675*695*1800	660	2~8	Double Glass	R 290a	590
Frozen Tower	4 Side Glass 5 Layers Panoramic Ventilated Freezer Showcase	5	Base + 4 shelves	650*650*1950	319	-18 ~ -22	Double Glass	R 290a	1000
DIVA 1200 Premia	Jewellery Box Type Display for chocolate & confectionery	1	Base + 2 Drawers	1200*850*1175	220	2~10	Heated #	R 134a	600
DIVA 900 Premia	Jewellery Box Type Display for chocolate & confectionery	1	Base + 2 Drawers	900*850*1175	160	2~10	Heated #	R 134a	500
Diva 42 Premia	Jewellery Box Type 2 Layer Display for chocolate & confectionery	1	Base + 2 Drawers	1200*850*1300		2~8	Heated #	R290	800
Baby Tower	Desk Top Tall Display Refrigerator	3	Base + 2 shelves	452*406*816	58	2~12	Double Glass	R 134a	190
Mini Tower	Desk Top Tall Display Refrigerator	4	Base + 3 shelves	430*390*986	78	2~12	Double Glass	R 134a	180
CTSR 23 Premia	Countertop 3 Layer Square Glass Cake Showcase	3	Base + 2 shelves	660*530*730	68	2~8	-	R 134a	160
CTSW 23 Premia	Countertop 3 Layer Square Glass Warm Showcase	3	Base + 2 shelves	660*530*730	68	40~65	-	-	450
CTSR 23	Countertop 3 Layer Square Glass Cake Showcase	3	Base + 2 shelves	660*530*730	68	2~8	-	R 134a	160
CTSW 23	Countertop 3 Layer Square Glass Warm Showcase	3	Base + 2 shelves	660*530*730	68	40~65	-	-	450
CTW 4	Countertop Warm Display Case	1	4 x GN 1/3 pans	773*420*336	67	30~90	-	-	500
FDW 3 x 660	Food Display Warmer with 3 Shelves	3	3 shelves	660*480*610	97	30~90	-	-	1480

Electricals: 220V/50Hz./Single Phase

Specifications are subject to change without prior notice due to continuous product development

Top glass also heated



India's favourite Commercial Microwave Oven

- ◆ Up to 100 programmable menu options for consistent results
- ◆ User friendly touch control pad
- ◆ 3 stage cooking and 5 microwave power levels
- ◆ See-through door with lighted interior
- ◆ Grab'n Go handle
- ◆ Stainless steel cabinet and oven cavity
- ◆ Removable splatter shield
- ◆ Stackable installation



Stainless Steel Cabinet
Glass Outer Window
Grab'n Go Handle

MWO 34DM



Stainless Steel Cabinet
Glass Outer Window
Grab'n Go Handle

MWO 25

Technical Specifications

Model	Dimensions W x D x H (mm)	Cavity Dimensions W x D x H (mm)	Cavity Volume (Litres)	Input Power (W)	Output Power (W)	Cooking Time (min:sec)
MWO 34DM	574 x 528 x 368	360 x 409 x 225	34	3000	1800	2:30
MWO 25	511x311x432	327x200x346	25	1550	1000	3:10

*Throughput reflects one piece of Pizza

Specifications are subject to change without prior notice

Biryani

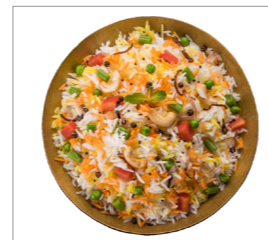

Biryani can be regenerated within minutes

Combo Meals



Combo meals can be regenerated within minutes

Lasagna



8 oz. lasagna can be cooked within 20 minutes and preheated in 3 minutes

Nachos



10 oz. nachos can be reheated within 2 minutes

Making fast food possible

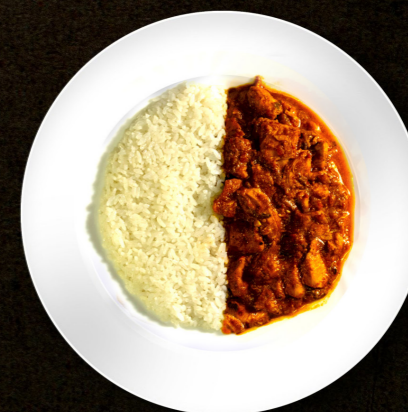



Turn fast food into a gourmet experience



Pratica **FIT** EXPRESS

SPEED OVENS

The American sensation, now in India

The Pratica Fit Express high-speed oven is gaining popularity worldwide. It is designed to efficiently finish refrigerated, fresh, or frozen foods, such as breakfast sandwiches, chicken wings, muffins, lasagnes, subs, and other partially prepared dishes. It provides excellent flavour, appearance, and crispiness. The combination of impinged air and microwaves allows for faster heating, browning, or toasting of foods compared to traditional methods.



FIT Express



CERTIFIED
VENTLES
 WITH EASILY REMOVABLE
 CATALYTIC CONVERTER.

- ◆ Compact size; suitable for 30cm pizzas.
- ◆ Full-colour, user-friendly touchscreen with drag-and-drop features.
- ◆ Stores menu recipes directly on the oven or via Wi-Fi or USB drive.
- ◆ Ventless: no hoods necessary.
- ◆ Removable catalytic converter for easy cleaning.
- ◆ Consistent results through precise control and even heat distribution.
- ◆ Independently adjustable microwave power, temperature, and impinged air.
- ◆ No side vents, allowing zero side clearance.
- ◆ Elegant and intuitive: stores unlimited recipes with their own steps, settings, icons, or photos.
- ◆ Temperatures up to 280°C: the impinged air convection technology combined with microwave capabilities enables faster cooking.
- ◆ Heat insulation keeps the surface cool to the touch.
- ◆ Single and dual magnetron versions available.

Standard Accessories

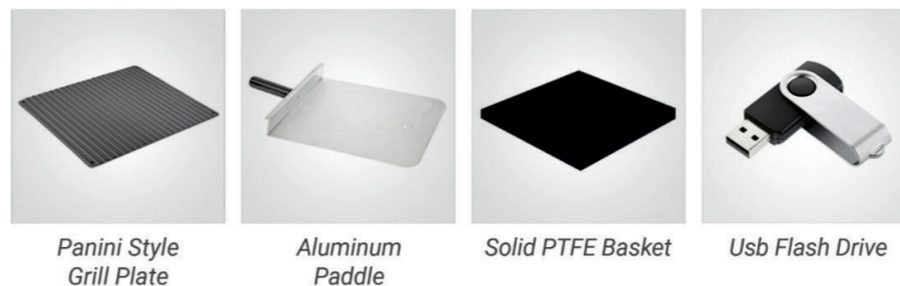

Market's most intuitive panel



Technical Specifications

Model	Voltage	Phases	Freq. (Hz)	Power (kW)	Circuit Breaker (A)	Cable	Socket	Product Dimensions (Width x Depth x Height)	Weight	Chamber Dimensions (Width x Depth x Height)
FIT Express	400V	Three	50	6.8	16	5x2,2mm ²	16A(3P+N+E)	386x693X619 (mm)	67 Kg	170x315x341 (mm)
FIT Lite	230V	Single	50	3	13	3x1,5mm ²	13A(2P+E)	386x680x619 (mm)	72 Kg	308x315x133 (mm)



Get great baking
results consistently



Modular Deck Ovens

The Butler Deck ovens offer you complete flexibility to stack multiple ovens on top of each other, enabling single-deck, double-deck, or triple-deck configurations. The Breadwinner series can also be placed atop the EDO series ovens shown on the facing page, providing various configurations for end users.



Breadwinner Series

- ◆ Boiler for effective steaming
- ◆ Single-deck two-tray version
- ◆ Modular: Can be stacked to create a 2-deck or 3-deck configuration
- ◆ Can also be paired with Black Italia Series ovens
- ◆ Digital controls with temperature setting up to 400°C

Black Italia Series

- ◆ Single-deck two-tray or 2-deck 4-tray models available
- ◆ Modular: Can be stacked to create a 3-deck configuration
- ◆ Can also be paired with Breadwinner Series ovens
- ◆ Comes with a stone that can accommodate 2 EN trays
- ◆ Digital controls with temperature setting up to 400°C



Breadwinner 1-2



Breadwinner 1-2
or EDO 1D-2T Black Italia
on top of

Breadwinner 1-2
or EDO 1D-2T Black Italia
or GDO 1D-2T Black Italia



EDO 2D-4T Black Italia
GDO 2D-4T Black Italia



Breadwinner 1-2
or EDO 1D-2T Black Italia
or GDO 1D-2T Black Italia
on top of

EDO 2D-4T Black Italia
GDO 2D-4T Black Italia

Technical Specifications - Deck Ovens 'Italia Series'



Product	Model	Power	Gas Consumption	Weight	Dimensions (W x D x H) mm	Electricals	Temperature	Trays
Electric Single Deck Oven with Steam Boiler, Stone and Digital Control	Breadwinner 1-2E	8.6 kW	-	-	1260x945x615	1-220V / 50Hz	0 ~ 400°C	2 x EN Trays
Electric Two Deck Oven with Steam Boiler, Stone and Digital Control	Breadwinner 2-4E	15.2 kW	-	-	1260x945x1240	3-380V / 50 Hz	0 ~ 400°C	4 x EN Trays
Gas Single Deck Oven with Steam Boiler, Stone and Digital Control	Breadwinner 1-2G	200 W	0.36 kg/Hr	120 Kg	1060x675x1150	1-220V / 50Hz	0 ~ 400°C	2 x EN Trays
Gas Two Deck Oven with Steam Boiler, Stone and Digital Control	Breadwinner 2-4G	200 W	0.58 kg/Hr	170 Kg	1330x840x1355	1-220V / 50Hz	0 ~ 400°C	4 x EN Trays
Electric Single Deck Oven	EDO 1D-2T Black Italia	6.6 kW	-	94 Kg	1260x855x565	1-220V / 50Hz	0 ~ 400°C	2 x EN Trays
Electric Two Deck Oven	EDO 2D-4T Black Italia	13.2 kW	-	161 Kg	1260x825x1100	3-380V / 50 Hz	0 ~ 400°C	4 x EN Trays
Gas Single Deck Oven	GDO 1D-2T Black Italia	100 W	0.28 kg/Hr	102 Kg	1330x840x650	1-220V / 50Hz	0 ~ 400°C	2 x EN Trays
Gas Two Deck Oven	GDO 2D-4T Black Italia	200 W	0.56 kg/Hr	170 Kg	1330x840x1355	1-220V / 50Hz	0 ~ 400°C	4 x EN Trays

Specifications are subject to change without prior notice due to continuous product development

Gas based ovens can work on LPG.





Electric Ovens & Proofers - Italia Series

This unified range of Butler Electric Ovens cum Proofers come in two variants - a 1 deck/ 2 tray or a 2 deck/4 tray electric oven built atop a 12 tray proofer. The outer cabinet is finished in brushed stainless. The oven is designed for baking bread, cakes, pastries and more. The required temperature can be set up to 400°C and controlled automatically. The 2 door proofer section at the bottom allows you to set the perfect temperature and humidity levels for consistent, repeatable results and can accommodate 12 pans (not supplied with the machines).



OVP 1212 Italia



OVP 1224 Italia

Technical Specifications - Electric Ovens & Proofers



Product	Model	Power/ Gas Pressure	Weight	Dimensions (W x D x H)	Internal Dimensions of Each Oven (W x D x H)	Electricals	Temperature
1 Deck 2 Trays Electric Oven With 12 Tray Proofer	OVP 1212 Italia	9.2 kW	125 kgs.	1300 x 830 x 1420mm	870 x 670 x 200mm	380V / 50 Hz	0-400°C (Oven) / 30-60°C (Proofer)
2 Deck 4 Trays Electric Oven With 12 Tray Proofer	OVP 1224 Italia	15.8 kW	210 kgs.	1300 x 830 x 1815mm	870 x 670 x 200mm	380V / 50 Hz	0-400°C (Oven) / 30-60°C (Proofer)

Specifications are subject to change without prior notice due to continuous product development

Trays not supplied with the machines.





Electric Convection Ovens

Butler convection ovens allow you to bake like a professional. They are designed for cooking or reheating croissants, chocolate buns, pastries or cookies, lasagna, baked potatoes and a wide variety of fresh frozen or pre-raised savories.

- ◆ Fan assisted heating ensures a quick rise in temperature up to 350°C
- ◆ Easy to clean chamber
- ◆ Double glass door; openable at 90° enables easy pullout of trays
- ◆ Advanced motor and heavy duty fan blades
- ◆ ECO-28-4T (New) comes with 4 trays



ECO 28-4T (New)



Technical Specifications



Model	Power	Dimensions W x D x H (mm)	Chamber Dimensions W x D x H (mm)	Temperature Range	Trays
ECO 28-4T (New)	4.5 kW	670 x 650 x 470	460 x 370 x 350	0°C - 350°C	4

Voltage: 220-240V/50Hz

Specifications are subject to change without prior notice due to continuous product development

The convenience of modularity

Prodigy



Convection Oven

- 3 fan speed control
- Reverse fan for uniform baking
- Steam spray (with water box)
- Auto door opening after each baking cycle
- 5 - 350°C
- Space for placement of 5 EN trays

Deck Oven with Stone

- Steam function
- High quality stone
- Advanced digital controls
- 0 - 350°C
- Space for placement of 1 EN tray

Proofer

- Advanced digital controls
- Space for placement of 8 EN trays
- 0 - 110°C

Little Prodigy





Prodigy - Convex

Prodigy - Convex Modular Electric Convection Ovens

The Prodigy Convex from Butler is a premium convection oven engineered for consistent, high-quality baking. It features steam regulation, three fan speed controls, reverse airflow, and an auto side-opening hinged door to prevent overcooking. With digital controls, capacity for 5 x 1 EN trays, and an AISI 304 stainless steel chamber, it is ideal for croissants, pastries, cookies and bread.



Little Prodigy - Convex

Little Prodigy - Convex Modular Electric Convection Ovens

A compact convection oven with steam regulation, three fan speeds, and reverse airflow for even baking. Featuring advanced digital controls, automatic door opening, and a stainless steel AISI 304 chamber, it holds 5 trays (440x332 mm) — ideal for small bakeries and café setups.



Prodigy - Deck

Prodigy – Deck Modular Electric Deck Ovens

The Prodigy Deck from Butler is a precision-built deck oven designed for consistent baking performance. It features digital controls, integrated steaming function, premium pizza stone, and an AISI 304 stainless steel chamber for uniform heat distribution. Ideal for pizzas, bread, croissants and baked goods.



Little Prodigy - Deck

Little Prodigy – Deck Modular & Compact Electric Deck Ovens

A powerful deck oven equipped with advanced controls, a premium pizza stone, steaming function, and an AISI 304 stainless steel chamber. Perfect for baking pizzas, breads, pastries, and more with consistent results.



Prodigy - Pro

Prodigy - Pro Modular Proofing Cabinets

The Prodigy Pro from Butler is a premium stainless steel proofer with capacity for 8 EN trays (trays not included). Its modular, stackable design allows integration with Prodigy Deck and Convex ovens within the same footprint. Optimized for efficient workflow and space utilization.



Little Prodigy - Pro

Little Prodigy - Pro Modular Proofing Cabinets

A stainless steel proofer designed to hold up to 6 trays (440 x 332 mm). Its modular design allows stacking with the Deck and/or Convex ovens, maximizing efficiency while saving valuable floor space.

Technical Specifications



Model	Power	Weight	Dimensions (W x D x H)	Cavity Dimensions (W x D x H)	Electricals	Temperature	Trays
Prodigy - Convex	6.0 kW	91 Kg	840 x 849 x 789mm	663 x 481 x 584mm	3-380V / 50Hz*	5 ~ 350°C	5 x EN Trays
Prodigy - Deck	4.7 kW	51 Kg	838 x 787 x 456mm	610 x 456 x 212mm	1-220V / 50Hz*	5 ~ 350°C	1 x EN Trays
Prodigy - Pro	0.5 kW	51 Kg	838 x 745 x 830mm	639 x 487 x 674mm	1-220V / 50Hz*	0 ~ 110°C	8 x EN Trays

Specifications are subject to change without prior notice due to continuous product development.
* Unit supplied with both single phase and three phase power supply

Technical Specifications



Model	Power	Weight	Dimensions (W x D x H)	Cavity Dimensions (W x D x H)	Electricals	Temperature	Trays
Little Prodigy - Convex	3.5 kW	-	636 x 669 x 639mm	486 x 350 x 456mm	1-220V / 50Hz	5 ~ 350°C	4 (400 x 332)
Little Prodigy - Deck	3.6 kW	-	635 x 687 x 456mm	450 x 444 x 212mm	1-220V / 50Hz	5 ~ 350°C	1 (400 x 332)
Little Prodigy - Pro	0.5 kW	-	636 x 647 x 647 mm	520 x 377 x 592mm	1-220V / 50Hz	30 ~ 110°C	6 (400 x 332)

Specifications are subject to change without prior notice due to continuous product development.
* Unit supplied with both single phase and three phase power supply



A wide range of pizza ovens



EPO 36 Black Italia
GPO 36 Black Italia



Neapolitan Forni Premia



EPO 1D Premia



EPO 2D Premia

Model	Power	Electricals	Temperature Range	Dimensions W x D x H (mm)	Output	Weight
EPO 36 Black Italia	3.2 kW	220 - 240V/50Hz	0-400°C	920 x 605 x 490	5kg/H	41 kg
GPO 36 Black Italia	100 W	220 - 240V/50Hz	0-400°C	1060 x 670 x 640	5kg/H	65kg
Neapolitan Forni Premia	5 kW	380V/50Hz	0-500°C	950 x 905 x 420	-	68 kg
EPO 1D Premia	2 kW	220 - 240V/50Hz	0-350oC	560 x 570 x 280	-	24kg
EPO 2D Premia	3 kW	220 - 240V/50Hz	0-350oC	560 x 570 x 440	-	33kg

*Gas Consumption: 0.24kg/hr Specifications are subject to change without prior notice due to continuous product development

Grill, Toast & more...





Contact Grills - Grooved

The Butler Euro Grill is an electric contact grill that is available in three variants featuring grooved top and bottom plates. These models are designed to leave grill marks and cook perfect jumbo-sized sandwiches, paninis, steaks, or hamburgers, retaining all juices and vitamins, or to grill fish, eggplant, or similar food items.



Euro Grill Junior DT



Euro Grill Jumbo



Euro Grill Jumbo DT

Technical Specifications

Model	Power	Temperature Range	Dimensions W x D x H (mm)	Cooking Surface (mm)	Net Weight
Euro Grill Junior DT	1.8 kW	50°C-300°C	290 x 305 x 210	218 x 230	13 Kg
Euro Grill Jumbo DT	2.2 kW	50°C-300°C	410 x 305 x 210	360 x 285	15.5 Kg
Euro Grill Jumbo	2.2 kW	50°C-300°C	410 x 370 x 220	360 x 285	15.5 Kg
Euro Grill (PG-11E)	2.8 kW	50°C-300°C	430 x 310 x 200	340 x 230	25 Kg
Euro Grill Premia (PG-11E Premia)	2.8 kW	50°C-300°C	425 x 400 x 210	340 x 230	21 Kg

Electricals : 220 V Specifications are subject to change without prior notice due to continuous product development

Electric Griddle Plates



EGP 730GF



EGP 730F



EGP 550 (New)

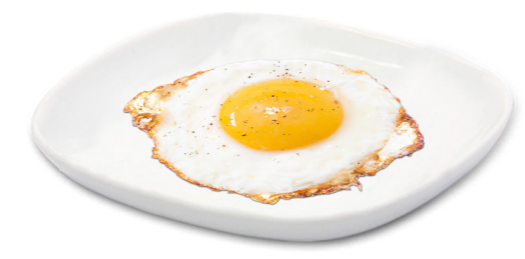

Technical Specifications

Model	Power	Electricity	Temperature Range	Dimensions W x D x H (mm)	Griddle Dimensions W x D x H (mm)
EGP 730 GF	4.8 kW	220V/50Hz/1Ph	50°C-320°C	730x470x250	728x468x10
EGP 550 (New)	3.0 kW	220V/50Hz/1Ph	50°C-320°C	500x400x260	498x298x10

Electricals : 220 V Specifications are subject to change without prior notice due to continuous product development



OMG 215 Premia



Multipurpose Grill

The OMG-215 from Butler is a multipurpose electric contact grill specially designed with flat top & bottom plates with a moulded cavity that makes it ideal for cooking or regenerating omelettes, paranthas, chillas, mini uttapams, mini dosas, pancakes or similar foodstuff that does not require grill marks. The round moulded cavity prevents fresh to be cooked omelettes or chillas or pancakes from overflowing or spilling while giving them a nice round shape.

- ◆ Easy to clean
- ◆ Timer and Touch Control Screen
- ◆ Cast iron plates for even cooking
- ◆ 10" diameter moulded cavity
- ◆ Self-balanced upper plate



Technical Specifications

CE

Model	Power	Temperature Range	Dimensions W x D x H (mm)	Electricals	Net Weight
OMG 215 Premia	1.8 kW	50°C-220°C	360 x 478 x 218	220V/50Hz/1Ph	15 Kg

Specifications are subject to change without prior notice due to continuous product development

Countertop Fryers with Auto Lift

The EF-12 Auto from Butler is a high-performance professional fryer designed for speed, consistency, and convenience. Its standout **auto-lift feature** raises the fry basket above the oil at the end of each cycle, allowing excess oil to drain back into the tank — ensuring perfectly cooked, less greasy results every time.

Equipped with **computerized touch controls**, it enables operators to multitask with ease while maintaining precise frying consistency. Built for busy fast food environments, it's ideal for preparing chips, chicken, fish, onion rings, and more in quick succession using minimal oil. **Removable components** make cleaning simple and efficient, supporting smooth daily operations.



EF 12 Auto

Technical Specifications



Model	Power	Capacity	No. of Baskets	Dimensions (W x D x H in mm)	Auto Lift	Voltage
EF 12 Auto	3 kW	12L	1	270x585x380	Yes	220V/50Hz

Specifications are subject to change without prior notice





EF 8 Europa DT



EF 4 Europa, EF 6 Europa,
EF 8 Europa



EF 8 Premia



EF 4, EF-6, EF 8



Countertop Fryers

These professional fryers from Butler are particularly suited for fast food restaurants. Suitable for frying chips, chicken, fish, onion rings in quick succession using minimal quantities oil. The model EF-8 Premia comes with computerised touch controls

- ◆ Precise bulb thermostat in stainless steel
- ◆ Heat resistant handles in baskets
- ◆ Removable parts for ease of cleaning
- ◆ 8 different models to choose from



Technical Specifications



Model	Power	Capacity	No. of Baskets	Dimensions (W x D x H in mm)	Voltage
EF 4 Europa	2 kW	4	1	220x400x315	220V/50Hz
EF 6 Europa	2.5 kW	6	1	265x430x290	220V/50Hz
EF 8 Europa	3.25 kW	8	1	265x430x340	220V/50Hz
EF 8 Europa DT	3.25 kW	8	1	265x430x340	220V/50Hz
EF 8 Premia	2.5 kW	8	1	280x430x310	220V/50Hz
EF 4	2 kW	4	1	220x390x370	220V/50Hz
EF 6	2.5 kW	6	1	260x410x285	220V/50Hz
EF 8	3.25 kW	8	1	260x410x340	220V/50Hz

Specifications are subject to change without prior notice due to continuous product development



IDF 08 (New)

Twice as fast as conventional fryers



IDF 08 Rise



Countertop Induction Deep Fryers

This pioneering product from Butler uses patented technology and is ideal for frying in those places where other forms of heating and cooking are avoidable. No flames or hot surfaces provide for a safer, cooler kitchen. They are a boon for food-courts, airports, railways stations and similar applications.

Key Features

- ◆ Touch control
- ◆ 10 Quick setting mode available with IDF 08 Rise to store 10 programmes
- ◆ Stainless steel body
- ◆ Temperature range: 60°C-190°C
- ◆ Default temperature: 140°C
- ◆ Timer range: 0 - 15 mins, multiples of 30 seconds each
- ◆ Auto power-off: 4 hrs

Technical Specifications



Model	Voltage	Power	Temperature Range	Dimensions (wxdxh)	Timer	Frypot Capacity
IDF 08 Rise	220-240V/50Hz	3500 W	60°C - 190°C	288x478x410mm	0-120 mins	8 Ltrs
IDF 08	220-240V/50Hz	3500 W	60°C - 190°C	288x478x410mm	0-120 mins	8 Ltrs

Specifications are subject to change without prior notice





Gelato Panini Grill

'Ice on Fire' from Butler is a new, exciting concept in the frozen dessert business that allows you to add an interesting dimension to your menu. This easy-to-use Panini Grill turns gelato, soft serve, ice cream, or frozen yogurt into a creamy delight sealed in a golden-toasted bun. Garnished or mixed with a savory or sweet topping, scrumptious Gelato Panini can be served sliced on a plate or as a full sandwich in an on-the-go wrapper. Warm on the outside, and cold on the inside, this novel treat is sure to light up your business.



Ice of Fire 100



Cut bun in half and add gelato, ice cream or frozen yogurt



Seal it with the other half of the bun and place in the cavity, press and cook

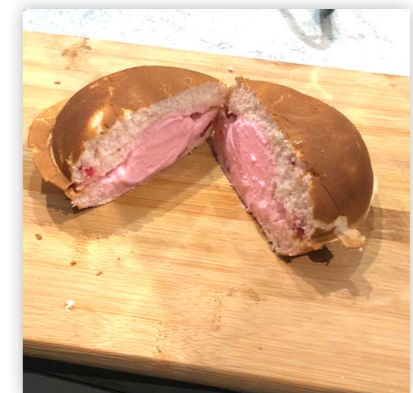

Cut the creamy burger into 2 or more pieces and serve

Technical Specifications



Model	Power	Electricals	Dimensions (WxDxH) mm
Ice on Fire 100	1300 W	220V/50Hz	250x540x315

Specifications are subject to change without prior notice



Waffle Bakers

The waffle bakers from Butler come with an electro-mechanical timer and can accept deep-frozen, frozen pre-cooked waffles or freshly made batter for making golden crispy waffles.

- ◆ Quick and even heat spread
- ◆ Temperature control range: 124°C ~ 230°C
- ◆ Time Control Range: 99 Minutes & 50 Seconds ~ 00 Minutes & 00 Seconds



WB 1



Technical Specifications

Model	Power	Weight	Temperature Range	Dimensions (W x D x H in mm)	Time Control Range
WB 1	2 kW	10 Kg	124°C ~ 230°C	250x450x300	50Sec ~ 99Mins

Voltage: 220-240V/50Hz

Specifications are subject to change without prior notice due to continuous product development



Chocolate Melter

The Butler Chocolate Melters are designed to not only melt your chocolate, but keep it at the perfect temperature throughout your food service. It comes with a covered stainless steel bowl, which is removable for easy cleaning. These can be used to melt Pure and Compound Chocolate, Hot Sauces and Chocolate Dips and more. It comes with a Temperature Controller to control the heat. Although the low wattage is designed to ensure that the chocolate does not get burnt, constant manual stirring is a must for optimal results.



CMM 4

Technical Specifications

Model	Dimensions W x D x H (mm)	Tank Dimensions W x D x H (mm)	Temperature Range	Capacity	Power	Net Weight
CMM 4	203x355x292	176x 325x100	30~95°C	4 Litre	800W	5.0 Kg

Electricals: 220V/50Hz/1 Phase

Specifications are subject to change without prior notice due to continuous product development

The craft behind
captivating blends



Commercial Blenders with Acoustic Enclosure - Premia series

The TruBlend AQ Premia is a powerful commercial blender designed for cafés, bars, and juice outlets. It features a digital control panel for precise, consistent blending and an advanced acoustic enclosure that reduces noise by up to 80%. With a rugged 1.5L jar, metal connectors, and heavy-duty blades, it crushes ice effortlessly for smoothies, frappes, milkshakes, and more.



TruBlend AQ Premia



Commercial Blenders with Acoustic Enclosure

The TruBlend Crush offers dependable commercial performance with easy manual controls, including a variable speed dial and pulse function for hands-on precision. Built for busy outlets, it crushes ice quickly and blends smoothies, shakes, and cold beverages with ease, while its acoustic enclosure ensures quieter operation.



TruBlend Crush



Commercial Blenders

The Butler TruBlend is a reliable commercial blender ideal for cafés, juice bars, and busy food outlets. With simple manual controls, a variable speed dial, and pulse function, it offers precise blending control. Powerful blades crush ice in seconds, making it perfect for smoothies, shakes, frappes, juices, and cold coffee. The pulse feature also allows quick jar cleaning between uses.



TruBlend 1.8T



Technical Specifications



Model	Dimensions (WxDxH) mm	Power	Motor Power	Jar Capacity	Net Weight	Timer
TruBlend AQ Premia	240x280x540	1500 W	2.25HP	1.8 Litre	11 Kg	Yes
TruBlend Crush	240x267x502	1680 W	2.25HP	1.8 Litre	8.85 Kg	Yes
TruBlend 1.8T	240 x 280 x 515	1680 W	2.2 HP	1.8 Litre	Yes	6.5 Kg

Voltage: 220-240V/50Hz

Specifications are subject to change without prior notice

Single Spindle Drink Mixers

The Butler Drink Mixers offer great versatility for mixing drinks as well as food preparation. They are ideal for mixing ice cream shakes, 'lassi' or bar drinks and are equally handy for blending eggs or mixing batter for pancakes or waffles.



DM 1M



Technical Specifications

Model	Power	Voltage	Shaft Speed (r/min)	Dimensions (WxDxH)	Net Weight
DM 1M	150 W	220~240V/50Hz	12000 / 18000	180x160x550 mm	4.3 Kg

Specifications are subject to change without prior notice due to continuous product development

Tireless performers

Refrigerated Reach in Cabinets

Trufrost Reach-Ins are available as Chillers or Freezers and come with 1, 2 or 4 door options. Suitable models for Coffee Shops come in 600 and 1200 litre capacities. Being vertical front door opening machines, they help save on precious space.



Models suitable for coffee shops →



G 600 TNM, G 600 BTM



G 1200 TNM, G 1200 BTM

Refrigerated Work Tables

Trufrost refrigerated work tables, mounted on heavy duty lockable castors, combine storage and preparation thereby enhancing the effectiveness of cafes and kitchen professionals. These are available as Chillers or Freezers and come with 2 and 3 door options



G 2100 TN, G 2100 BT



G 3100 TN, G 3100 BT



S 901



Technical Specifications



Product	Model	Cooling System	Product Dimensions W*D*H (mm)	Volume (Litres)	Product Weight (Kg)	No. of Doors / Drawers	No. of Shelves	Temperature Range (°C)	Refrigerant	Input Power (W)
Reach In Refrigerators	G 600 TNM	Ventilated	680*710*2010	600	115	2	3	2~+10	R134a	220
	G 1200 TNM	Ventilated	1340*710*2010	1200	152	4	6	2~+10	R134a	465
Reach In Freezers	G 600 BTM	Ventilated	680*710*2010	600	126	2	3	-22~-18	R404A	615
	G 1200 BTM	Ventilated	1340*710*2010	1200	161	4	6	-22~-18	R404A	580
Undercounter Refrigerators	G 2100 TN	Ventilated	1360*600*850	228	83	2	2	2~+10	R134a	240
	G 3100 TN	Ventilated	1795*600*850	339	102	3	3	2~+10	R134a	230
	S 901	Static	900*700*850	240	69	2	2	+2~+10	R134a	180
Undercounter Freezers	G 2100 BT	Ventilated	1360*600*850	228	92	2	2	-22~-18	R404A	615
	G 3100 BT	Ventilated	1795*600*850	339	114	3	3	-22~-18	R404A	615

Electricals: 220V/50Hz/1 Phase Specifications are subject to change without prior notice due to continuous product development
Please refer to information given next to the product picture.



Ice Machines

Highly relevant for commercial outlets where space is at a premium, the self contained Trufrost Ice Machines present the best options for coffee shops and restaurants and can also be used for undercounter applications.

- ◆ Contemporary, elegant design available in ice production capacities ranging from 18 to 910 kg per day
- ◆ Insulated ice storage bin and door minimize air condensation and water formation
- ◆ IC 18BW also comes with a cold water dispensing option
- ◆ IC 35BWA & IC 50BWA models have the option of accommodating a bottled water jar on top
- ◆ IC-25 Premia, IC35BWA, IC-50BWA & IC-100 models are also suitable for undercounter applications so long the recommended circulation space can be provided for the discharged hot air from the machine.
- ◆ IC-25 Premia can also be placed over the counter.



Technical Specifications



Model	Capacity / 24 hrs.*	Ice Storage Capacity	Cube Shape / Size (mm)	Refrigerant	Electricals	Power (w)	Dimensions wxdxh (mm)	Compatible Storage Bin
IC 25 Premia	25 kgs.	6.0 kgs.	Dice / 28*28*23	R404a	220V/50Hz	180	380*470*600	-
IC 35 BW Premia	30 kgs.	15 kgs.	Dice / 28*28*23	R404a	220V/50Hz	280	500*450*830	-
IC 55 BW Premia	50 kgs.	18 kgs.	Dice / 28*28*23	R404a	220V/50Hz	320	500*590*830	-
IC 55 BW Premia XL	50 kgs.	18 kgs.	Dice / 35*35*23	R404a	220V/50Hz	320	500*590*830	-
IC 100 Premia	98 kgs.	45 kgs.	Dice / 28*28*23	R404a	220V/50Hz	600	660*680*930	-
IC 220 Premia	220 kgs	150 kgs.	Dice / 28*28*23	R404a	220V/50Hz	850	560*830*1600	ISB-150
IC 350 Premia	350 kgs.	220 kgs.	Dice / 28*28*23	R404a	220V/50Hz	1200	760*830*1600	ISB-220
IC 460 Premia	460 kgs.	220 kgs.	Dice / 28*28*23	R404a	220V/50Hz	1600	760*830*1800	ISB-220
IC 1000 Premia	950 kgs.	460 kgs.	Dice / 28*28*23	R404a	380V/50Hz	4500	1220*930*1980	ISB-460

* At 10°C incoming water and 10°C air temperature Height & width for IC 220/350/460/1000 is with the suggested storage bin
 Specifications are subject to change without prior notice due to continuous product development

Flat Packed Stainless Steel Furniture

The knocked down stainless steel furniture range from Butler perfectly complements its cooking and food preparation equipment. Built in solid 0.8mm stainless steel, it is easy to install and aims to comprehensively address the equipment needs of commercial kitchens.



Work Tables with Splash Back



WT.1200SB

Work Tables



WT.1200

Stands with 4 shelves



4S.1400, 4S.1500, 4S.1800

Single Layer Wall Shelves



OHS 1200

Technical Specifications

Model	Description	Dimensions (WxDxH) mm
WT.1200SB	Work Table with Splash Back - 1200 mm	1200*700*850+100
WT.1200	Work Table - 1200 mm	1200*700*850
4S.1400	Stand with 4 shelves - 1400mm	1400*500*1800
4S.1500	Stand with 4 shelves - 1500mm	1500*500*1800
4S.1800	Stand with 4 shelves - 1800mm	1800*500*1800
OHS 1200	Overhead shelves - 1200mm	1200*350*700

Specifications are subject to change without prior notice

Cake, coffee
& more



Scan the QR codes given below to download other catalogues for

- 1 Bakeries
Confectionery 

- 2 Commercial Kitchens
Cloud Kitchens 

- 3 Cafés
Patisseries 

- 4 Pizzerias
QSRs 

- 5 Ice Cream Parlours
Juice Bars 

- 6 Resto-bars
Pubs 

- 7 Food Retail
Supermarkets 

- 8 Food Preservation
Cold Storage 

**TRUFROST
& BUTLER**

Trufrost & Butler Pvt. Ltd.

Formerly, Trufrost Cooling Pvt. Ltd.

1215, 12th Floor, Tower B, Emaar Digital Greens,

Golf Course Extn. Road, Sector 61, Gurugram - 122011, India

Tel: +91-124-4246560 Email: info@trufrost.com www.trufrost.com

Andhra/Telangana : 7042027666
 Chennai : 7303890587, 9289143691
 Chhattisgarh : 7303890590
 Coldroom (North): 8448445701, 7303196612
 Coldroom (South): 9319399771, 7303890585
 Delhi/NCR : 8448759200, 7303890582
 Goa : 7303196614

Gujarat : 9319579748
 Assam/North-East : 9319391542, 9667795491
 J & K / Himachal : 9717664894
 Karnataka : 7303890588, 9289143696
 Kerala : 9717664984, 7303890587
 Maharashtra : 7303890586
 Mumbai : 7303196614, 9319579748

Orissa : 7303890590, 9667795491
 Punjab / Haryana : 8448319200, 9319399772
 Rajasthan : 8448759200
 UP : 7303196607
 MP : 7303890582
 Uttarakhand : 8448319200, 9319399772
 West-Bengal/Bihar : 7303890590, 9667795491

Reach-in Cabinets • Undercounter Refrigeration • Blast Freezers • Ice Cubers • Flake Ice Machines • Wine Coolers • Wine Walls • Back Bars • Bottle Coolers • Draught Beer Systems
 Soft Serve Freezers • Granita Dispensers • Juice Dispensers • Hot Chocolate Dispensers • Confectionery Display Cases • Chest Freezers & Coolers • Minibars • Multideck Chillers
 Deli Counters • Visi Coolers • Visi Freezers • Walk-in Coldrooms • Cold Storages • Pre-Coolers • Ultra Low Freezers • Pharmacy Freezers & Coolers • Blood Bank Refrigeration • Mobile Coolers
 Air Sanitisers • Crockery & Cutlery Sterilisers • UV Warm Wipe Sterilisers • Ozone Fruits & Vegetables Disinfectors • Foot Press Water Dispensers



Discover more at
www.trufrost.com