

**TRUFROST & BUTLER**

**USER** **MANUAL**  
**Cake Showcases**

**We thank yo`u for your choice of Cake Showcase. Please read this operating manual carefully before using it in order to get the most out of your showcase.**

### MAIN TECHNICAL PARAMETERS

Type	Storage temperature	Voltage/ Frequency	Input total power	Refrigerant	Dimensions(mm)
CSF 24 Premia	2~8°C	220~240V 50Hz	390W	R290	600*700*1300
CSF 34 Premia			445W		900*700*1300
CSF 44 Premia			465W		1200*700*1300
CSF 54 Premia			625W		1500*700*1300
CSF 34 Max			425W		900*660*1300
CSF 44 Max			465W		1200*660*1300
CSF 54 Max			640W		1500*660*1300
Crystal Tower Premia			590W		675*675*1900
CTSR 23 Premia			250W		660*530*730
3 Plus 2 Premia			930W		(660+900)*700*1300
CSF 24 Max			420W		660*660*1300
DIVA 900 Premia			450W		900*850*1170
DIVA 1200 Premia			680W		1200*850*1170
DIVA 42 Premia			800W		1200*850*1300
Temptation 44 Premia			625W		1200*730*1300
DIVA 900 Golden	450W	900*850*1175			
CSF 45 TAll Premia	995W	1200*740*1900			
DI-515	0~12°C	500W		515*535*1470	
CTSW 23 Premia	40~60°C	450W	/	660*530*730	
WSF 24 Premia	40~60°C	870W	/	600*700*1300	
WSF 44 Premia	40~60°C	1500W	/	1200*700*1300	

Type	Storage temperature	Voltage/ Frequency	Input total power	Refrigerant	Dimensions(mm)
CTSS 5	2~8°C	220~240 /50Hz	220W	R134a	1340*420*315
Wow Gelato 12	-18~-22°C		1200W	R404a	1260*1045*1373

### SAFETY PRECAUTIONS:

- This cake display cabinet should be placed in an environment where there is adequate circulation of air , in the shade, in a cool/dry place, away from direct sunlight or a heat source and also not in too high ambient temperature environment. Power supply to be used must meet the voltage range to be within 10% more or less than the specified voltage on the name plate on the machine. If the voltage is not stable, a power stabilizer about 5 times of the total power input is necessary.
- Please use a three-pin electrical socket with proper earthing. (The earth wire should not be allowed to be connected to a tap water pipe or a gas pipe)
- Never use fuel, easy-exploding and corrosive things near the showcase.
- Please do not operate the temperature control knob with wet hands.
- This appliance is not intended for use by children or persons with reduced physical, sensory or mental capabilities, or who lack experience and knowledge, unless they have been given supervision or instruction concerning use of the appliance by a person responsible for their safety.
- Children should be supervised to ensure that they do not play with the appliance.
- The food placed on the shelves should be arranged uniformly and equitably, each shelf could load 10 kg at most.

### HOW TO OPERATE

- Avoid placing too much food items in the cake display cabinet. Some space should be allowed between the food , so as to allow a certain airflow. Open the door as less as possible. Do not leave the door open while the machine is on. This will be detrimental to the cooling efficiency of the appliance and can put an over-load on the condensing unit and the compressor can tend to get damage

- All food should be stored in clear plastic food-boxes or plastic fresh-keeping film in order to not only avoid pollution but also prevent moisture loss and to reduce frost-building on the evaporator.

EXPLODED DIAGRAM:

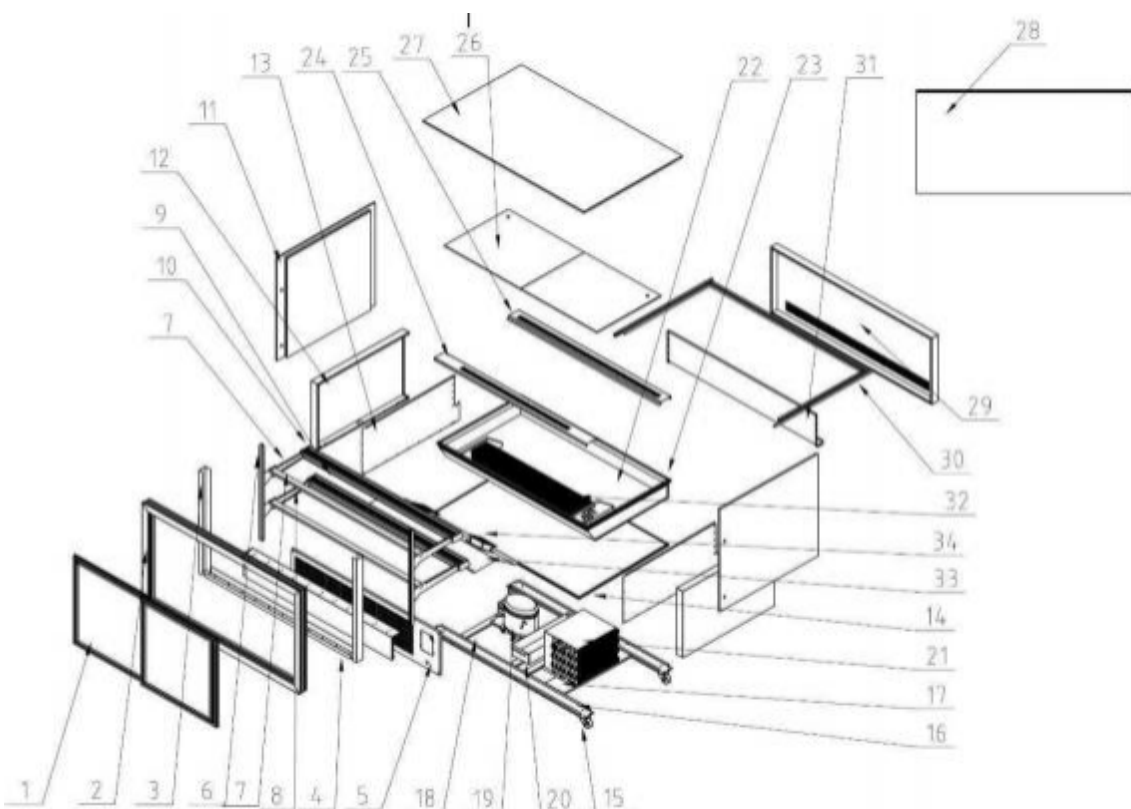
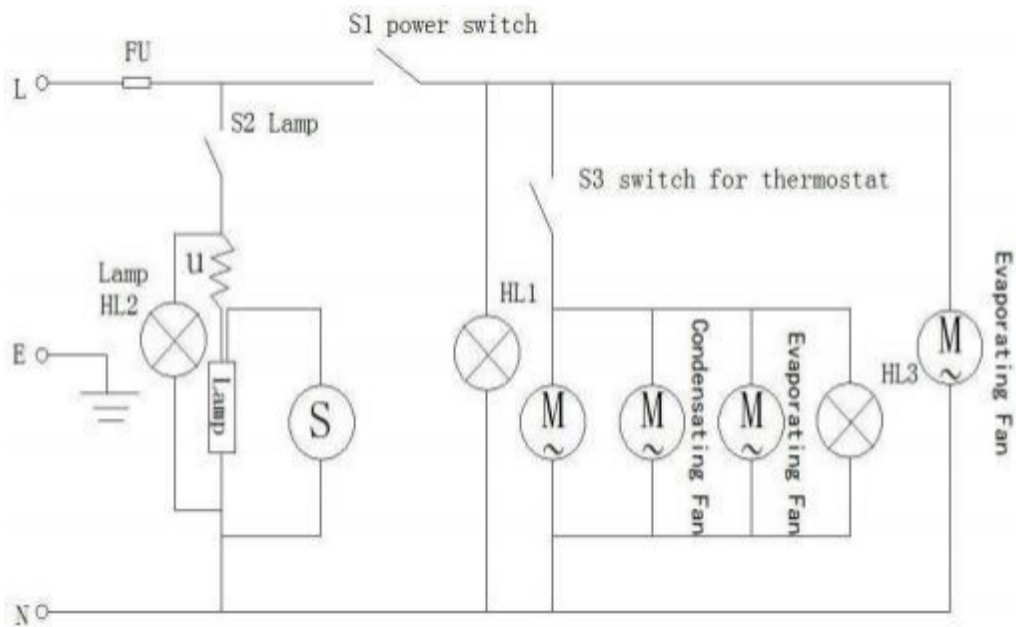

1	Hollow glass door	13	Foamed frame side sealing plate	25	Return air grille
2	Doorframe	14	Foamed frame bottom shell	26	Bottom plate
3	Column side panel	15	2 inch universal wheel	27	Roof glass
4	Doorframe crossband bottom	16	Underframe support plate	28	Front baffle glass
5	Switch panel	17	Condenser support plate	29	Foamed frame front plate
6	Ladder	18	Compressor support plate	30	( PVC ) Glass bottom
7	Bracket	19	Compressor	31	Foamed frame front sealing plate
8	Shelf back crossbar	20	( PVC ) Water	32	Evaporator
9	Lampshade (aluminium alloy)	21	Condenser	33	Fan plate
10	( PVC ) Lampshade	22	Inner tank component	34	Evaporator fan
11	Sideboard glass	23	Component (PVC)		
12	Foamed frame sideboard	24	Air outlet		

## SERVICE AND MAINTENANCE

- ☛ Please regularly clean the condenser once in everyone or two months. Much dirt or dust restricts the airflow and lowers the radiation effect.
- ☛ When washing the condenser , please pull off the plug first , and open the shutter, wrap the electric units and the joints with plastic film. Dust can be cleaned by compressed air or tap water. Dirt can be cleaned by the means of drenching 1:20 NaOH solution slowly on the condenser. After the dirt is absolutely dissolved , clean it by tap water. (Attention: You can connect the power and start the machine only after the condenser system has fully dried)
- ☛ The installation of the appliance and the refrigerant condensing unit must only be made by authorized service personnel.
- ☛ If the supply cord is damaged, it must be replaced by the authorized service personnel in order to avoid a hazard.

**COMMON PROBLEMS & TROUBLE SHOOTING**

<b>Problem/Symptom</b>	<b>Possible cause</b>	<b>Remedy</b>
<ul style="list-style-type: none"> <li>No power input</li> </ul>	<ul style="list-style-type: none"> <li>Fuse broken</li> <li>Poor contact between plug &amp; socket</li> <li>Input control circuit faulty</li> </ul>	<ul style="list-style-type: none"> <li>Replace the fuse</li> <li>Repair and replace the socket</li> <li>Inspect it by instrument or meter</li> </ul>
<ul style="list-style-type: none"> <li>Compressor does not work</li> </ul>	<ul style="list-style-type: none"> <li>Thermostat faulty</li> <li>Thermostat is not set properly</li> <li>Thermostat's contact is poor</li> <li>Plug of starter is loose</li> <li>Compressor faulty</li> <li>Starter or capacitor faulty</li> </ul>	<ul style="list-style-type: none"> <li>Replace it</li> <li>Set thermostat</li> <li>Insert the connector tightly</li> <li>Insert the pin tightly</li> <li>Replace it</li> <li>Repair or replace it</li> </ul>
<ul style="list-style-type: none"> <li>Compressor works continuously but temperature in the cabinet does not comedown</li> </ul>	<ul style="list-style-type: none"> <li>Ambient temperature is too high, and/or the set temperature on thermostat is</li> <li>too low</li> <li>Too many stains on condenser</li> <li>Too much frost on evaporator</li> </ul>	<ul style="list-style-type: none"> <li>Set the thermostat properly the</li> <li>Clean condenser</li> <li>Defrosting in time, adjust defrosting cycle, increase the defrosting time</li> </ul>
<ul style="list-style-type: none"> <li>Condenser's fan does not run</li> </ul>	<ul style="list-style-type: none"> <li>Fan's capacitor faulty</li> <li>Fan motor's bearing lack oil</li> <li>Fan motor coil damaged</li> </ul>	<ul style="list-style-type: none"> <li>Replace it</li> <li>Fill oil</li> <li>Replace it</li> </ul>
<ul style="list-style-type: none"> <li>Compressor starts and stops too frequently</li> </ul>	<ul style="list-style-type: none"> <li>Compressor coil short circuit</li> </ul>	<ul style="list-style-type: none"> <li>Measure it use universal meter, replace the compressor</li> </ul>
<ul style="list-style-type: none"> <li>Light does not glow</li> </ul>	<ul style="list-style-type: none"> <li>Light faulty</li> <li>Circuit contact is bad</li> </ul>	<ul style="list-style-type: none"> <li>Measure it use universal meter, replace it</li> <li>Again connect well</li> </ul>
<ul style="list-style-type: none"> <li>The fan of the evaporator does not work</li> </ul>	<ul style="list-style-type: none"> <li>Poor contact of the socket</li> <li>The fan motor damaged</li> </ul>	<ul style="list-style-type: none"> <li>Repair or replace</li> <li>Replace</li> </ul>

**Don't get alarmed in case of the following:**

- The water flowing sound is normal and indicates flow of when the refrigerating agent.
- Surface is hot when the compressor is in operation. However, avoid touching the hot surface of the compressor by your hand.

**Note**

1. The electric circuit diagram and parameters on the product name plate are final ones if they have been changed.
2. The design might be improved without notice.
3. If the supply cord is damaged, it must be replaced by the manufacturer, its service agent or similarly qualified persons in order to avoid a hazard.

**TRUFROST AND BUTLER PRIVATE LIMITED**

1214 & 1215, Tower B, Emaar Digital Greens,  
Golf Course Extn. Road, Sector 61, Gurugram – 122011, Haryana, India  
T. +91-7303166766 info@trufrost.com  
[www.trufrost.com](http://www.trufrost.com)