

TRUFROST & BUTLER

USER MANUAL

**Desktop Flat Glass Ice Cream
Scooping Display:
DTF-3**

Desktop Flat Glass Ice Cream Scooping Display

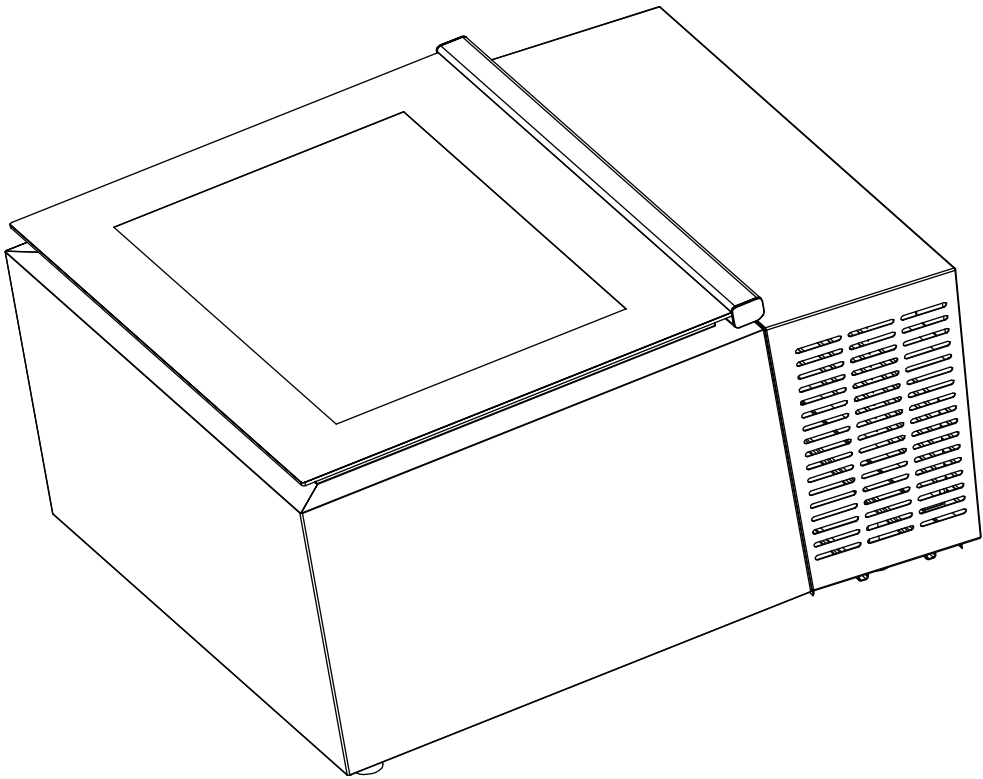

- Please read this manual carefully before use
- Please keep it for your reference

Before use

Directory.....	1
Part of the component name	2
Safety Precautions	3
Place environment	4

Start Enable

Preparation before use	5
Defrost	5
Boot operation and temperature adjustment	6

Maintenance and repair

Clean · Deactivate · Answer Questions	7
After sale service	8

Circuit diagram · Packing list	9
--------------------------------	---

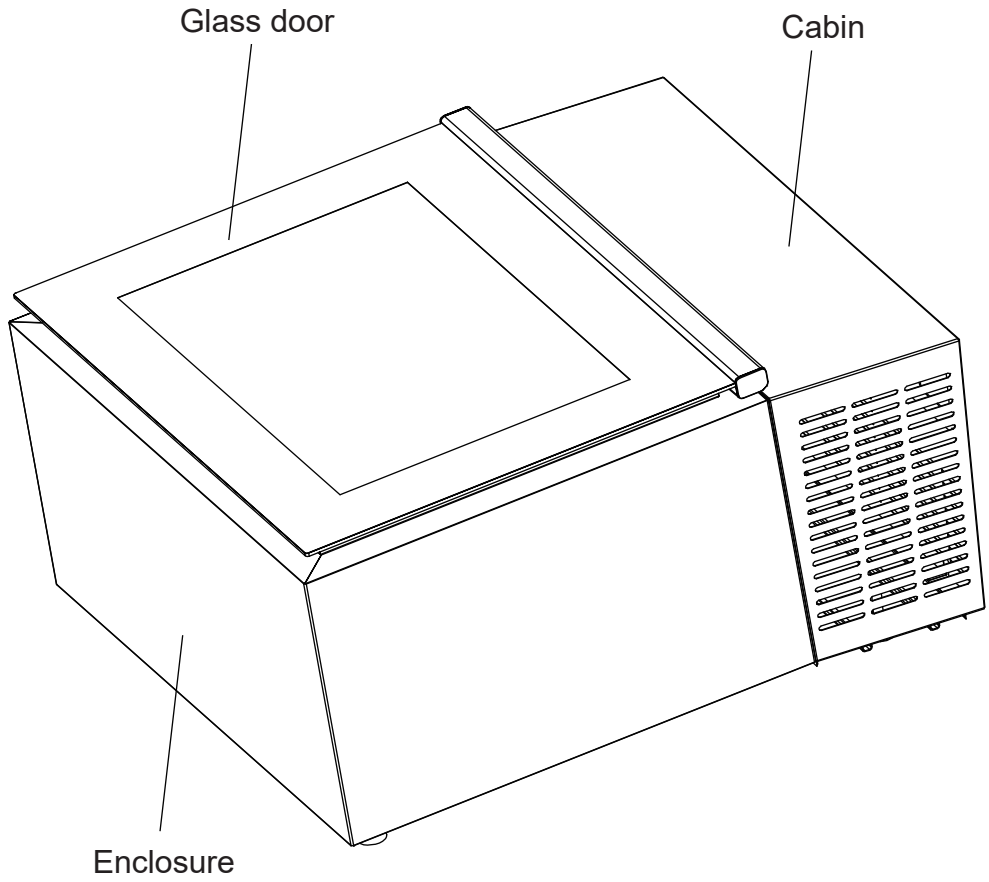

Safety Precautions

Only the local voltage frequency can be used.



Must use independent special socket and reliable grounding. After the freezer is placed, the plug should be in a position easily accessible to hands. Warning! Keep the plug of the power cable firmly in contact with the socket; otherwise, it may cause fire.



Flammable and explosive dangerous goods, strong corrosive acid and alkali are strictly prohibited in the freezer.

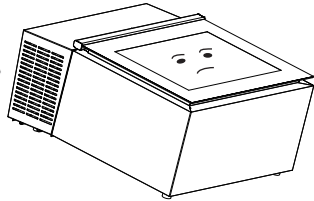

Do not use flammable sprays near to avoid fire.

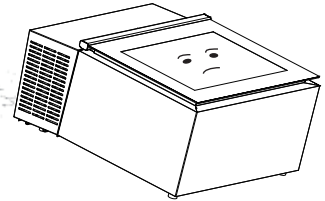

When flammable gas such as gas leaks:

- ◆ Close the gas leakage valve;
- ◆ Open doors and Windows;
- ◆ Do not unplug or insert the power plug of the freezer.



Do not disassemble or modify the freezer without permission. Do not damage the refrigeration pipes. Only professional personnel can repair the freezer.

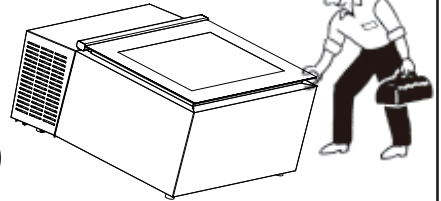

If the power cable needs to be extended, the cross-sectional area of the extended cable should not be smaller than the diameter of the power cable.

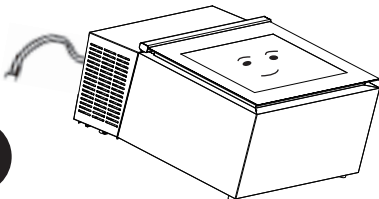

The freezer is strictly prohibited to store living organisms, medicines, flowers and other items with very strict temperature requirements.

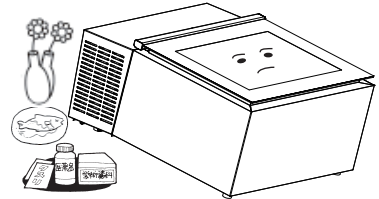

Once the power is disconnected from the freezer, it takes five minutes to reconnect it. To avoid damage to the compressor or system. For maintenance, the power plug must be unplugged. Do not pull out the power plug by pulling the power cable, and do not leave the freezer. Hold down the power cord or step on the power cord artificially. Please be careful when handling, Bind the power cables. Do not roll or damage the power cables.

Place environment

The freezer should be placed smoothly and the bag should be evacuated. Install base to reduce vibration and noise. When moving, the inclination angle should not be greater than 45° to avoid damage to the system.

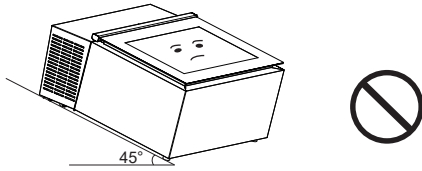

Do not use the pipe, door, or box as the focus to avoid the system or container is damaged.

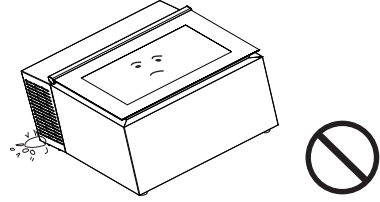

Leave a certain space around the freezer (10cm between the back and sides) for ventilation and heat dissipation.

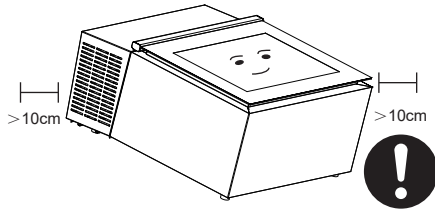

The freezer should be placed in a place away from direct sunlight and heat sources.

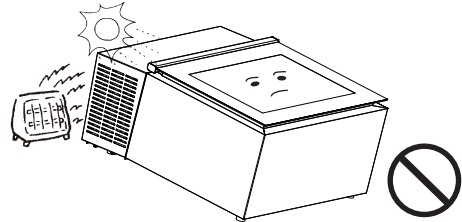

The freezer should be placed in a dry place, such as long time in wet or with water place, will affect the electrical insulation strength. Do not leave outdoors or shower use where it rains.

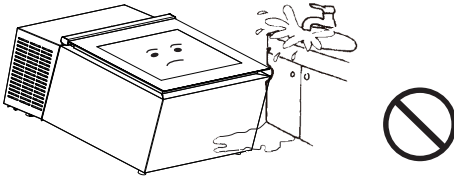

Do not store in too cold (below 5°C) environment.

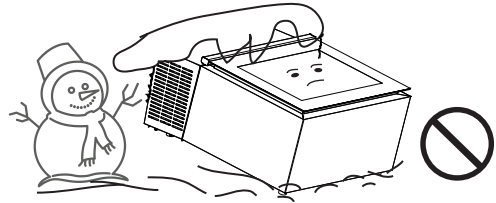

Preparation before use

1. Remove all packing components

Before using the freezer, remove the packing case, including the base.

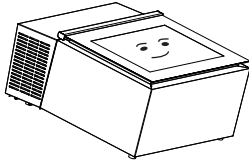

2. Check the attachments and data

Please check the "Packing list" for the quantity of goods in the case. Content control examination.



3. Clean the freezer before use

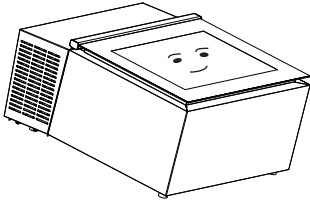

See the "Cleaning" section below for detailed instructions.

4. Foot adjustment

Adjust the foot according to the ground condition to make the freezer stable, to reduce vibration and noise.

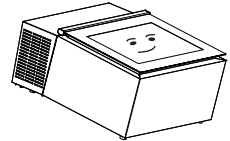

Note: The distance between the bottom of the box and the ground is not less than 20mm (the height of the box can be adjusted by adjusting the foot)

5. Let it sit

After the freezer is moved, let it stand for 30 minutes above can be connected to the power supply.

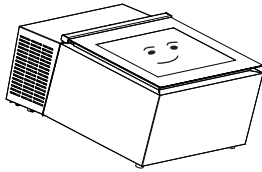

Defrost

To improve the refrigeration effect, defrost the inner wall of the frozen pantry when the thickness of the frost layer reaches 5mm.

1. Cut off the power supply and put the items in an insulated container. After the frost softens, defrost with a defrosting shovel.
2. After defrosting, wipe the inner wall dry with a rag, and then switch on the power supply.



Do not defrost with sharps or any other electrical equipment.

Boot operation and temperature adjustment

Run in use

Do not immediately put the ice cream box into the freezer that has just been connected to the power supply.
After the empty freezer runs for a period of time (about 1 hour), then put the ice cream in the cupboard for storage.

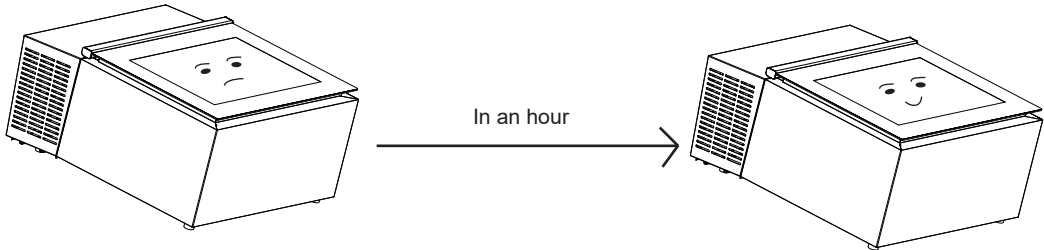

Regulation of temperature



- ◆ The temperature inside the freezer affects the ice cream's temperature and feel.
The ice cream is too cold and hard to hit,
Increase the temperature of the thermostat by 1 or 2 gears (for example, from 5th to 3rd);
The ice cream is warm and soft to the ball,
Turn down the thermostat by 1 or 2 gears (for example, from 4 to 6).

Clean·Deactivate·Answer Questions

Clean·Deactivate·Answer Questions

1. For safety, please unplug the power before cleaning.
2. When cleaning the freezer, use a soft cloth or cotton cloth dipped in water or soap (any non-corrosive neutral detergent can be used).Clean with a dry cloth after cleaning to prevent rust.
3. Do not clean the freezer with organic solvents, boiling water, laundry detergent or acids.
4. Do not rinse the freezer with water during cleaning; Do not use a stiff brush or wire brush to clean the freezer.

Out of service

If the freezer is to be stopped for a long time, the power supply should be cut off and cleaned according to the above method.And open the glass door, dry the items in the cabinet before sealing.If you need to discard this freezer, should be away from the fire, to the designated processing site for processing.

Answering questions

The following symptoms are not faults

Now like	Cause and Treatment
There was a sound of liquid running in the freezer	It is the sound of refrigerant flow in the circulation pipeline of the refrigeration system. It is a normal phenomenon and need not be dealt with.
Glass door and front of freezer Condensation appears along the lower edge of the window	If the air humidity is too high, dry it with a soft cloth.

- ◆ During use, if you find any questions, please compare this manual carefully. Check whether it is caused by improper operation. If the fault persists, contact your local after-sales service center.
- ◆ If the power cable is worn or damaged, you must go to the maintenance site designated by the manufacturer or ask qualified personnel to replace it.
- ◆ Before you discard this product, please remove the sealing strip to prevent children from playing with it.

After sale service

Any product has the possibility of failure. Please observe the operation of the freezer in time during use. If there is any abnormality in the stored food, please check and deal with it according to the following table. If you can't change the situation, you should when notifying the company's service centers around the country, so as not to cause loss to you.

The freezer doesn't work

Please check the circuit first:

- ◆ Check that the fuse is in good condition
- ◆ Whether the plug is in poor contact with the socket
- ◆ Whether the input and control lines are faulty

The compressor runs without stopping

If the temperature inside the cabinet is not cold enough. Please check:

- ◆ Check whether the air supply and return ports of the engine compartment are blocked
- ◆ Whether the door was left open or opened too many times
- ◆ Whether the ambient temperature is too high

Excessive noise

- ◆ Whether the freezer is placed unsteadily
- ◆ Whether a part of the cabinet is in contact with external objects or walls

After-sales Service Matters

Under any of the following circumstances, chargeable repair shall be carried out:

- ◆ Products whose warranty has expired.
- ◆ Damaged due to poor transportation, storage and failure to operate according to the instructions.
- ◆ Damaged due to voltage beyond the specified local range or voltage instability.
- ◆ Self-disassembled or repaired products outside the factory warranty point.
- ◆ Product warranty, invoice, product number, the product on the warranty the product whose serial number does not match the product number sent for repair or has been altered.

Circuit diagram • Packing list

Circuit diagram

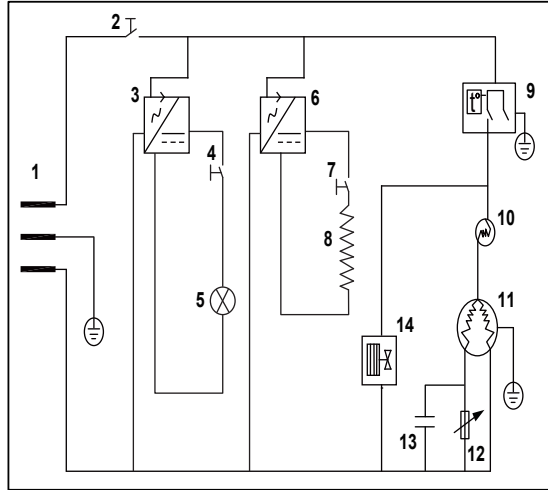

1.Power Plug 2.Power Supply Switch 3.Switch Power 4.Light Switch

5.LED Light 6.Switch Power 7.Heating wire switch 8.Heating Wire

9.Thermostat 10.Motor Protector 11.Compressor 12.Starter

13.Capacitor Optional 14.Fan

◆ Note: If the product has been improved, the technical data and circuit diagram shall be subject to the circuit diagram of the nameplate on the box.

Packing list

Instruction Manual	Defrosting shovel
1	1

◆ Note: If the product is improved, the right to change each part of the freezer is reserved. We beg your pardon without further notice.



warning

After the appliance is discarded, it should be properly disposed of or handed over to professionals. It should not be discarded randomly. So as not to cause harm to the environment or cause other dangers!

TRUFROST AND BUTLER PRIVATE LIMITED

1214 & 1215, Tower B, Emaar Digital Greens,
Golf Course Extn. Road, Sector 61, Gurugram – 122011, Haryana, India
T. +91-124-4246560 info@trufrost.com
www.trufrost.com