



USER MANUAL

Pizza Dough Roller: PDR-40

1. Installation

1.1 Remove the protection film, avoid contact with utensils that can damage the surfaces, check that machine is not damaged. Please contact with the manufacturer if it is damaged.

1.2 The machine must be installed in dry, adequate ventilation and lighting environment condition. Position the machine on a flat and firm place; you can put it on a workbench whose height fits you (about 700-900 mm), and leave a space around it of 150 mm for easier usage and cleaning.

1.3 Connect the machine to the electric net by an electric technical personnel. It is suggested that using copper wires (at least 2.5 mm²) for the electric wires. It is important to have a good ground system and a protection switch (5-10A).

1.4 It is necessary for safety to check the cable carefully and verify it is not damaged before put the plug to the receptacle. The receptacle must be easily accessible, must not require any kind of movement. The cable from the machine to the receptacle must not be pulled tightly, also do not rest the machine on the cable.

Note : The machine has been installed and tested by technical personal before leaving the factory, and it is a qualified production. It is not allowed to disassemble or modify the machine without the permission of the manufacturer, or we do not pay if any loss.

2. Operation

2.1 The machine has the following control devices on the front panel:

A--Red button to stop the machine

B--Green button to start the machine

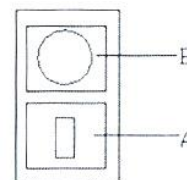

2.2 Functional test

After having plugged the feeding cable in the electric net, the machine is ready for the functional test. To start: press the green button, the machine starts working. To stop: press the red button, the machine will stop working. Start the machine without loading, let it run for one minute and make sure it is functioning perfectly.

2.3 Before every work-cycle, always make sure the machine is perfectly clean, in particular those surfaces that get in touch with the dough. If necessary clean the machine.

Warning: Take sundries and hands away from the rollers before turn on the machine!

2.4 Operation for the shaping of round disks

2.4.1 After turning on the machine, you can put the small dough(20-500g) which

have ferment previously (at least 4 to 6 hours), squash the sides slightly and put some dry flour on it so it can easily go through the upper rollers. (Pict.1)

2.4.2 When the dough comes out from the upper roller, you will see thin dough, with an oval shape. You can turn the dough to 90° place by hand rapidly, and ready for the next trial to through the lowest rollers. Out of these rollers it will have a disk shape, this shape is not perfect so it needs the finishing touches by hand. Pict.2

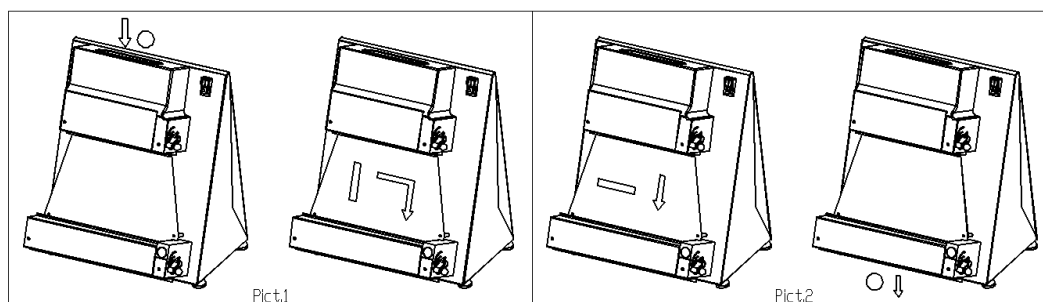

2.5 Usage for the shaping of rectangles, squares, and others.

The methods are the same as the point 2.4. If you want to obtain different shaping dough, you can cut the dough to the approximate shape, for example squares, rectangle etc. with a knife or a special tool, before introducing the small dough in opening of the highest cover. Then introduce the dough in opening of the highest cover and let it through the roller. You can choose it as following: A) let the dough only through the highest rollers. B) let the dough through both the highest rollers and the lowest rollers. C) let the dough through the highest roller, then turn the dough 90° place by hand rapidly, and let it through the lowest rollers.

2.6 How to regulate the thickness

Regulating the machine can only be recommended as there are different characteristics of: the dough, the weight, the thickness, the size and the shape of the disk. Therefore, the correct regulating of the machine must be made by experience. The machine is provided with a medium size regulation for the shapes of pizza. To obtain different thickness of dough, you may regulate as following:

A) Turn off the machine.

B) Regulate the width between the highest rollers. Pull the black knot in order to release the lever, and then turn the lever to a proper position. Clockwise is to reduce the thickness, anti-clockwise is to increase the thickness. (Pict.3)

EX : the width between the upper rollers is twice to the one between the lo rollers.

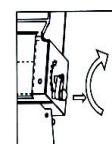

3. Warning

Warning : To avoid dangerous conditions and/or possible injuries caused by electric current, mechanical parts, fire or hygiene problems, you must follow the safety indications step by step :

- 3.1 Keep in order your working area. Disorder can cause dangerous accidents.
- 3.2 Consider environmental conditions. Do not use the machine in humid, wet or badly lit environments, close to inflammable liquids or gas.
- 3.3 Keep away from children and non authorized personnel. Do not permit them to go near the machine or the working area.
- 3.4 Do not touch the switch and the cable with a wet hand.
- 3.5 Only utilize the machine with the correct voltage. Normal usage gives better results.
- 3.6 Dress in adequate way. Do not wear hanging clothes or any items which can be caught in the machine. Use non-slip shoes. For hygiene and safety, keep your hair tied back and wear protective gloves.
- 3.7 Protect the cable, do not put the cable to extract the plug. Do not leave the cable near high temperatures, sharp objects, water or solvents.
- 3.8 Take the plug out. When the machine is not in use, before cleaning, maintenance and moving it.
- 3.9 Check that the machine is not damaged. Before using the machine, carefully check that all safety devices are working. Check that: the removable parts are not blocked, there are not any parts damaged, all the parts have been set up correctly and all the conditions that could influence the regular functioning of the machine are in working order.
- 3.10 When the machine is damaged or some anomalies with it, you must turn off the machine at once and apply for authorized assistance from the manufacturer. The repairs can only be done by qualified people, using original spare parts. The non-compliance with these rules can represent danger for the user.

4. Maintenance

- 4.1 Before effecting any kind of maintenance or cleaning you must take out the plug. It is important not to use chemical, abrasive or corrosive products. Absolutely do not use running water, abrasive and not smooth tools, such as metal wool etc; these can damage the surfaces and compromise the hygienically safety.
- 4.2 The cleaning must be done every time the machine has been used following all

the rules to prevent malfunctioning of the machine and for hygienic purposes.

4.3 Using a proper brush and a wooden palate, first clean the residue of flour and dough, take them away from the covers, the two slides A, release springs B, C, remove the scraping dough pieces D then turn the regulating levers L-L1 in position of maximum opening of rollers.

Accurately clean the machine and in particular the disassembled parts using a sponge or cloth damped with water and detergent.

Rinse thoroughly and dry with an absorbing food-paper, wipe again all the surfaces that get in touch with the dough and then clean the whole machine with a smooth cloth and specific disinfectant for food-machines.

4.4 Mount everything in this order: the scraping dough pieces, the springs, the slides and the protections.

4.5 Lubrication of shafts and rollers

It is necessary to grease shafts and rollers every year. Take off the protections, the slanted wall, the springs and the dough-scrappers; unscrew the fixing screws and take off first the back-panel A and then the stands B and C; take off the rollers DEFG and the joints H I L M. clean all these parts accurately by means of a sponge; warm (page 9) water and food detergent, rinse thoroughly and dry it with absorbing paper. grease both the shafts and the rollers holes with a sufficient quantity of paraffin oil. Put back on and fix all the parts, starting from the last taken off piece.

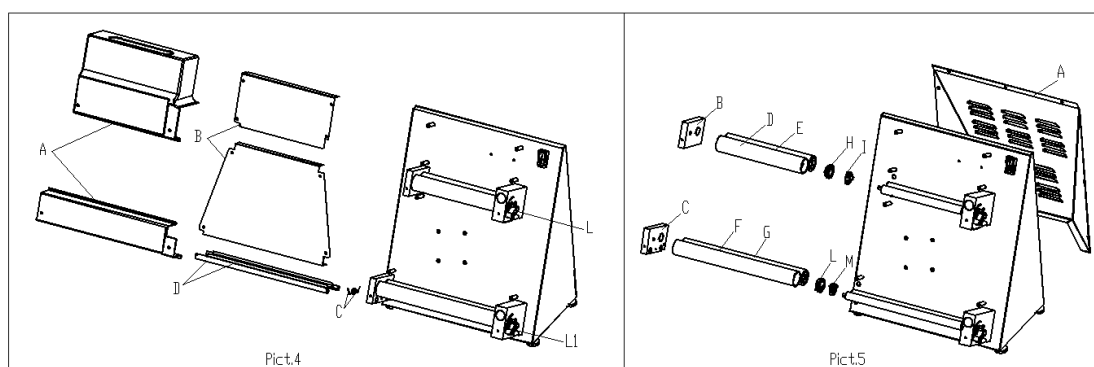

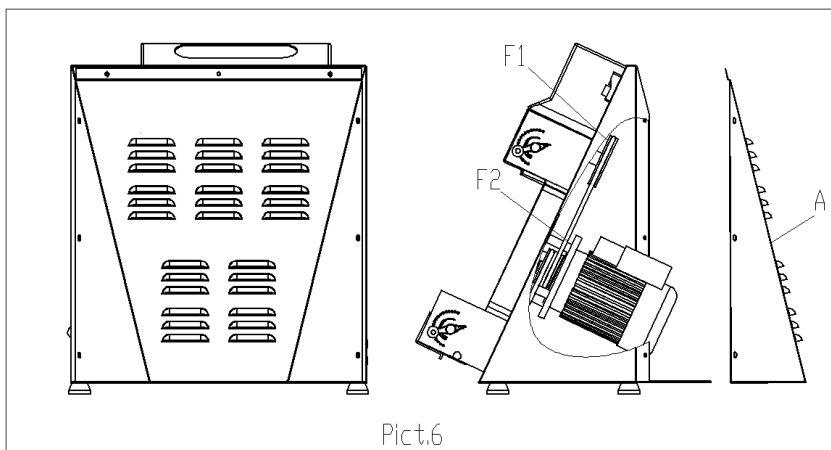

Pict.6

5、 Possible anomalies

anomaly	cause	solution
The machine does not start	1、 Electrical power is missing 2、 the input voltage is wrong. 3. other reasons	1、 Check the general switch, the plug and the feeding cable 2、 use a proper voltage. 3. stop using and apply for authorized assistance from the manufacturer.
The machine conduct electricity	The wires touch the structure of the machine.	Check the wires, verify the wires do not touch the structure of the machine.
Only a group roller working	1. the belt is broken. 2. the worm wheel is worn out.	1. change the belt. 2. change a new worm wheel.

6、 Specification

Model	APD30	APD40
Voltage (V)	~220	~220
Frequency (Hz)	50	50
Motor power(kW)	0.37	0.37
Dough weight(g)	50-500	50-500
Pizza diameter(cm)	10-30	10-40
Dimension(mm)	495*490*640	540*550*650

7、 Electrical diagram

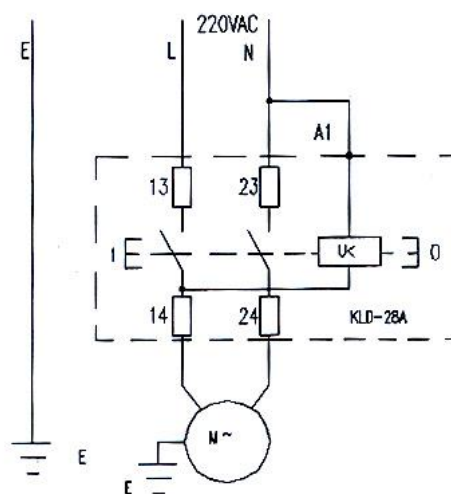

KLD: Switch M: Motor
 FA: Thermo-protection of the engine

Marketed globally by:

TRUFROST COOLING PRIVATE LIMITED

1215, 12th Floor, Tower B, Emaar Digital Greens, Golf Course Extn. Road,
Sector 61, Gurugram – 122102

T. +91-7303166766 info@trufrost.com

www.trufrost.com