

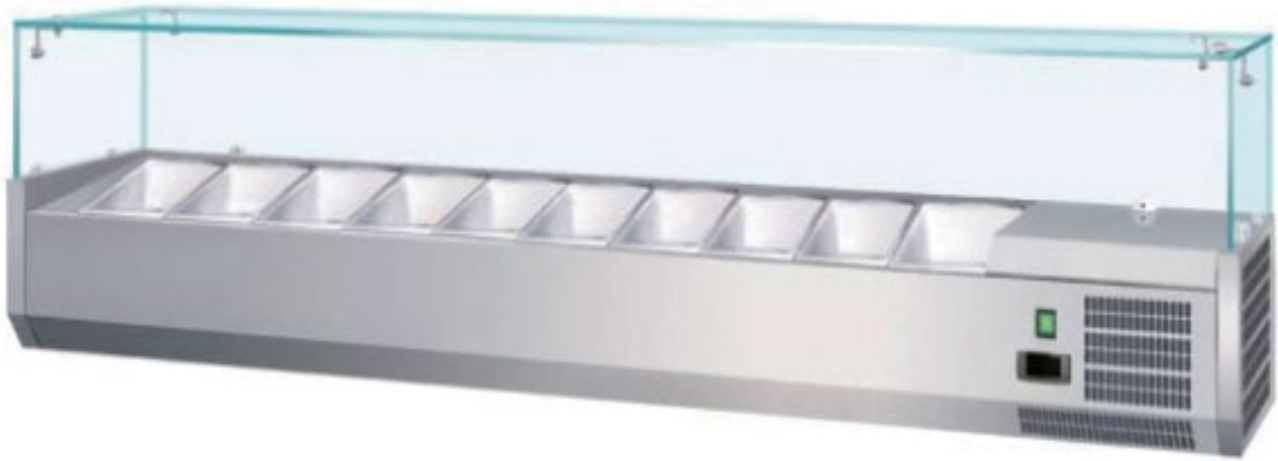

# **USER MANUAL**

**Counter Top Display: VRX 1200/300**





### GLASS ASSEMBLY GUIDE

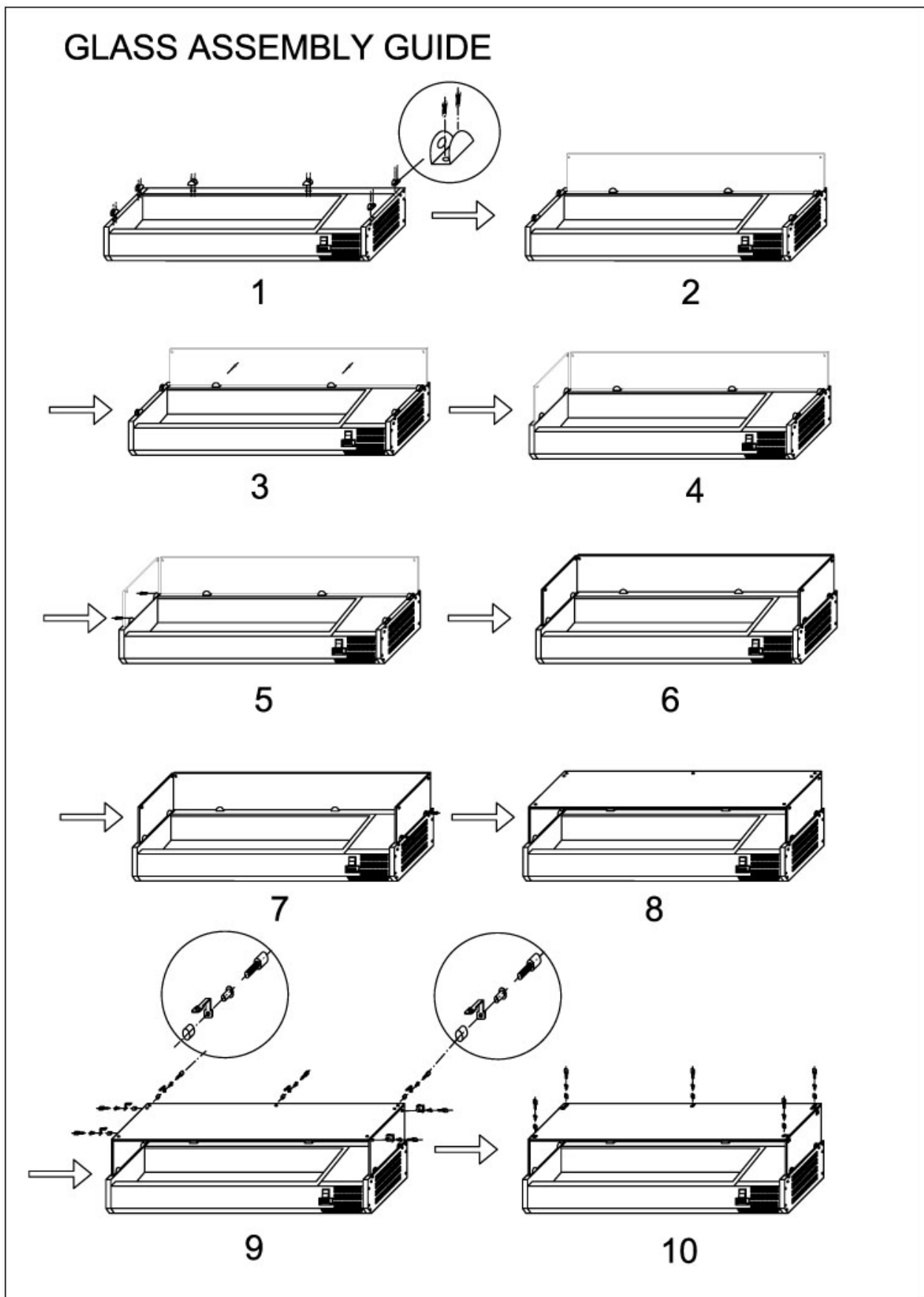

# Table of Contents

Safety Tips .....	6
Introduction .....	6
Installation.....	6
Fit Glass Panels.....	7
Operation .....	8
Storing Food .....	8
Turn On.....	8
Cleaning, Care & Maintenance .....	8
Cleaning the Condenser .....	8
Troubleshooting .....	9
Technical Specifications .....	10
Electrical Wiring .....	10
Disposal .....	10
Compliance .....	10

## Safety Tips

- Position on a flat, stable surface.
- A service agent/qualified technician should carry out installation and any repairs if required. Do not remove any components or service panels on this product.
- Consult Local and National Standards to comply with  
The following:
  - Health and Safety at Work Legislation
  - BS EN Codes of Practice
  - Fire Precautions
  - IEE Wiring Regulations
  - Building Regulations
- DO NOT use jet/pressure washers to clean the appliance.
- DO NOT use the appliance outside.
- DO NOT use this appliance to store medical supplies.
- DO NOT use electrical appliances inside the appliance.  
(e.g. heaters, ice-cream makers etc.)
- Always carry, store and handle the appliance in a vertical position and move by holding the base of the appliance.
- Always switch off and disconnect the power supply to the unit before cleaning.
- Keep all packing away from children. Dispose of the packaging in accordance with the regulations of local authorities.
- If the power cord is damaged, it must be replaced by an agent or a recommended qualified technician in order to avoid a hazard.

## Introduction

Please take a few moments to carefully read through this manual. Correct maintenance and operation of this machine will provide the best possible performance from your product.

We pride ourselves on quality and service, ensuring that at the time of packing the contents are supplied fully functional and free of damage.

Should you find any damage as a result of transit, please contact your dealer immediately.

## Installation

**Note: If the unit has not been stored or moved in an upright position, let it stand upright for approximately 12 hours before operation. If in doubt allow the appliance to stand.**

1. Remove the appliance from the packaging. Make sure that all protective plastic film and coatings are thoroughly removed from all surfaces.
2. Maintain a distance of 20cm (7 inches) between the unit and walls or other objects for ventilation. Increase this distance if the obstacle is a heat source.

**Note: Before using the appliance for the first time, clean the shelves and interior with soapy water.**

3. Level the appliance by adjusting the screw feet.

## Fit Glass Panels(optional)

1. Screw the collars to the rim of the appliance.

**Note: Ensure the hole in the collar for the grub screw face Inwards.**

2. Slot the two side panels into the collars, with the holes in the glass at the top.

**Note: Ensure the screw hole furthest from the edge of the panel goes to the back of the appliance.**

3. Screw a grub screw into each collar to secure the panels.

**Note: Ensure the soft end of the grub screw is the end making contact with the glass.**

4. Slot the rear panel into the collars, with the holes in the glass at the top.
5. Screw a grub screw into each collar to secure the panel.
6. Slot the plastic plugs into each of the holes.
7. Screw the brackets to the inside of each pane using the bolt assemblies.

**Note: Ensure the short end of the bolt assembly is on the outside of the panels.**

8. Place the top panel onto the brackets, ensuring all holes line up.
9. Insert the plugs and attach the top panel to brackets with the bolt assemblies.

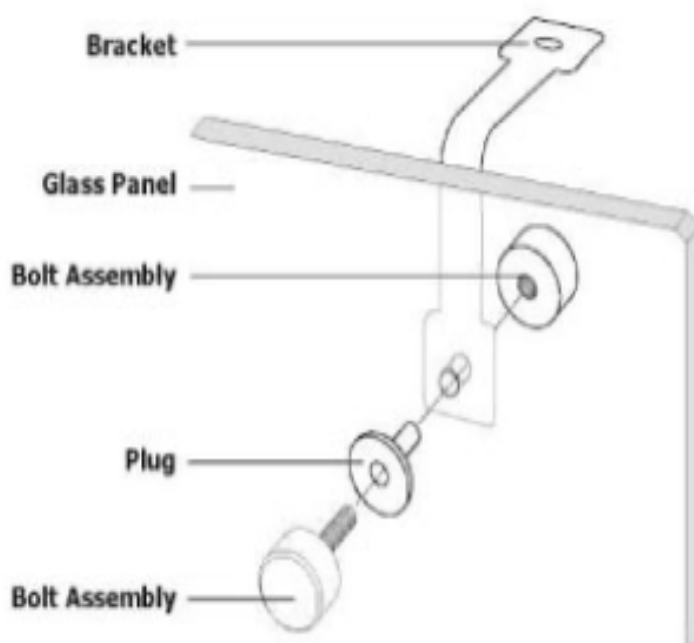

## Operation

### Storing Food

To get the best result from your appliance, follow these instructions:

1. Only store foodstuffs in the appliance when it has reached the correct operating temperature.
2. Do not place uncovered hot food or liquid inside the appliance.
3. Do not obstruct the fans inside the appliance.

### Turn on

1. Close the door(s) of the appliance.
2. Ensure the power switch is set to [O] and turn on at the socket.
3. Switch on the power [I]. The current temperature within the appliance is displayed.

### Cleaning, Care & Maintenance

- Switch off and disconnect from the power supply before cleaning.
- Clean the interior of the appliance as often as possible.
- Do not use abrasive cleaning agents. These can leave harmful residues.
- Clean the door seal with water only.
- Always wipe dry after cleaning.
- Take care when cleaning the rear of the appliance. Sharp edges can cut. An agent or qualified technician must carry out repairs if required.

### Cleaning the Condenser

Periodically cleaning the condenser is mandatory and failure to do so will void the warranty.

We recommend that our agent or qualified technician clean the condenser.

## Troubleshooting

If your appliance develops a fault, please check the following table before making a call to your dealer.

<b>Fault</b>	<b>Probable Cause</b>	<b>Action</b>
The appliance is not working	The unit is not switch on	Check the unit is plugged in correctly and switched on
	Plug and lead are damaged	Call your agent or qualified technician
	Fuse in the plug has blown	Replace the fuse
	Power supply	Check power supply
	Internal wiring fault	Call your agent or qualified technician
The appliance turns on, but the temperature is too high/low	Too much ice on the evaporator	Defrost the appliance
	Condenser blocked with dust	Call your agent or qualified technician
	Doors are not shut properly	Check doors are shut and seals are not damaged
	Appliance is located near a heat source or air flow to the condenser is being interrupted	Move the refrigerator to a more suitable location
	Ambient temperature is too high	Increase ventilation or move appliance to a cooler position
	Unsuitable foodstuffs are being stored in the appliance	Remove any excessive hot foodstuffs or blockages to the fan
	Appliance is overloaded	Reduce the amount of food stored in the appliance
	The discharge outside is blocked	Clear the discharge outlet
	Movement of water to the drain is obstructed	Clear the floor of the appliance (if applicable)
	The water container is damaged	Call your agent or qualified technician
The drip tray is over flowing	Empty the drip tray (if applicable)	
The appliance is unusually loud	Loose nut/screw	Check and tighten all nuts and screws
	The appliance has not been installed in a level or stable position	Check installation position and change if necessary

### Technical Specifications

Model	Voltage	Power	Current	Temperature Range	Capacity	Dimensions HxWxD (mm)	Weight (kg)
VRX1200/330	220 ~ 240V/50Hz	115W	1.1A	2~10°C	5xGN1/4 Container	430x1200x335	25

## Electrical Wiring

Appliances are supplied with a 3 pin, moulded, BS1363 plug and lead, with a 13 amp fuse as standard. The plug is to be

connected to a suitable mains socket. Appliances are wired as follows:

- Live wire (coloured brown) to terminal marked L
- Neutral wire (coloured blue) to terminal marked N
- Earth wire (coloured green) to terminal marked E

All appliances must be earthed, using a dedicated earthing circuit.

If in doubt consult a qualified electrician.

Electrical isolation points must be kept clear of any obstructions. In the event of any emergency disconnection being

required they must be readily accessible.

## Disposal

EU regulations require refrigeration product to be disposed of by specialist companies who remove or recycle all gasses, metal and plastic components.

Consult your local waste collection authority regarding disposal of your appliance. Local authorities are not obliged to

dispose of commercial refrigeration equipment but may be able to offer advice on how to dispose of the equipment locally.

## Compliance

Parts have undergone strict product testing in order to comply with regulatory standards and specification set by

international, independent, and federal authorities.

Products have been approved to carry the following symbol:



**TRUFROST COOLING PRIVATE LIMITED**  
1214 & 1215, Tower B, Emaar Digital Greens,  
Golf Course Extn. Road, Sector 61, Gurugram – 122011, Haryana, India  
T. +91-7303166766      info@trufrost.com  
[www.trufrost.com](http://www.trufrost.com)