



USER MANUAL

Spiral Mixers:

SM-20T, SM-34T, SM-45T

Technical Data

Model	SM-20T	SM-34T	SM-45T
Bowl Capacity (L)	21	34	45
Voltage	220V / 50Hz	220V / 50Hz	220V / 50Hz
Power (kW)	1.5	1.5	1.8
Max.Quantity (kg)	8	12	16
Mixing Speed (r/min)	150/200	150/200	150/200
Bowl Speed (r/min)	15/20	15/20	15/20
Weight (kg)	85	100	115
Dimension (mm)	730 x 390 x 900	435 x 750 x 900	800 x 480 x 970

1. Installation and Power Link

- ① Take apart the package then place the equipment steadily. Spiral mixer usually does not need bed installation.
- ② Make sure the rated voltage of the equipment. The power wires should be connecting to the power source through a creepage-protector. The yellow/green wire is used for grounding connection. The wiring terminal on the backside of the equipment is equipotential wiring terminal.

2. Operation

- ① Before use, make sure the input voltage is confirm to the rated voltage of the equipment. The equipment is placed steadily and the grounding connection is safety.
- ② Check to see if the fixation of the material bowl and the mixer are reliable.
- ③ Get through the power; test the equipment without anything inside the bowl. Make sure the turn direction is the same as the arrow marked. If not the same, user should exchange the wiring. The three machines need to test whether the machines fast and slow buttons match the actual speed of the machine and if not ,change the wires that feed the buttons.
- ④ Pour wheat flour into the bowl, add water, and then put down the “slow speed” button to start mixing. After a fur minute, put down the “high speed” button to work.
- ⑤ Before take out the dough from the bowl, please cut off the power first.

3. Maintenance and cleaning.

- ① Please cut off the power source after use. Keep the equipment clean. Don't use spout to wash the equipment.
- ② Check the adjust the belt and the tightness of the chain periodically. Add Ca lubricant.

4. Breakdowns and Settlements

Phenomenon	Cause	Settlement
The mixer doesn't work	Electricity lose contact	Check the circuit
The shaft tremble	Fixed nut loose	Screw the fixed nut
Temperature of the motor raise The turn speed low down	1.Voltage too low	1.Check the power source
	2.The belt loose	2.Tighten the belt
	3.Overloaded.	3.Don't overload.
The mixer touches the bowl side.	The mixer or the bowl becomes deformed.	Adjust or replace it.

5. Safety Cautions

- ① When the equipment is working, prohibit putting hands or other things into the bowl.
- ② Don't overload.
- ③ Don't drive the belt or chain by hands in case the hand would be injured.
- ④ Don't work too long continuously.
- ⑤ Avoid children approaching the equipment when it is working.
- ⑥ Must cut off the power source first when repair the equipment.

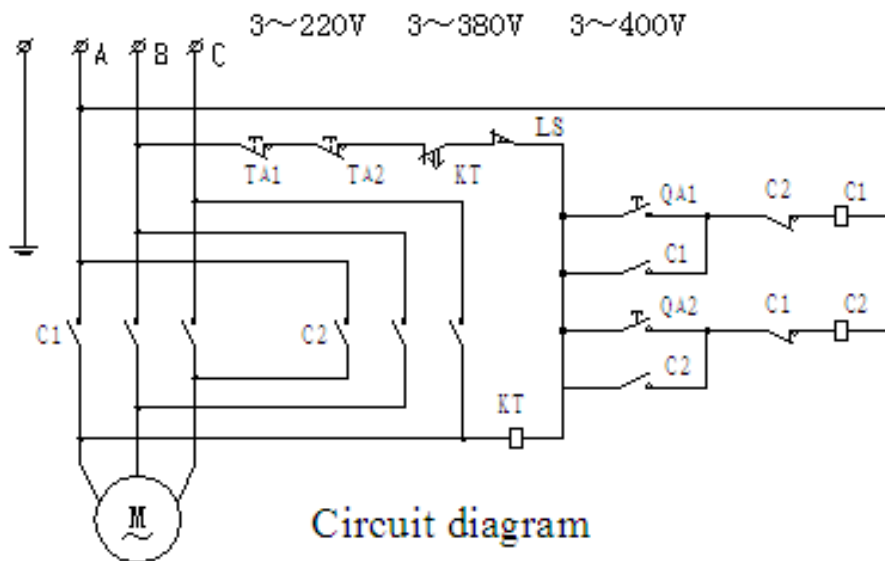
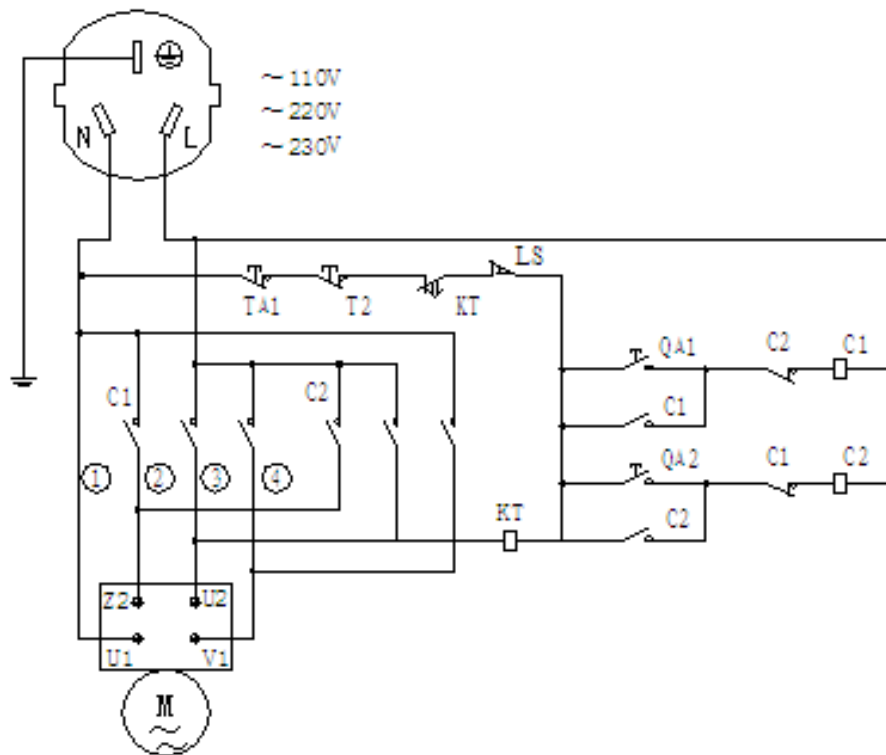

Circuit diagram

Code	Name	Code	Name
QA	Start butting	C	A.C.contactor
TA	Stop butting	M	Motor
KT	Timer	LS	Limit switch

Marketed globally by:

TRUFROST COOLING PRIVATE LIMITED

1215, 12th Floor, Tower B, Emaar Digital Greens, Golf Course Extn. Road,
Sector 61, Gurugram – 122102 (India)

T. +91-124- 4246560 info@trufrost.com

www.trufrost.com